

Hand & power tools

KITCHEN AND CABINET BATHROOM MAKING

Supporting:

LMFFM2001B:

Use furniture making sector

hand and power tools



Learner guide

Developed in 2013-2014 for the WELL Program

Hand and power tools Learner guide

This unit is also available in an e-learning format, which contains additional photos, interactive exercises and a voice-over narration of the text. It can be viewed on CD-ROM, or live on the web at:

www.kbcabinetmaking.com.au



Developed by Workspace Training for the 2013-2014
Workplace English Language and Literacy (WELL) Program
Kitchen and Bathroom Cabinetmaking resource development project





Copyright and disclaimer

ISBN: 978-1-925087-07-9

Funded under the Workplace English Language and Literacy Program by the Australian Government through the Department of Industry.

© Commonwealth of Australia. 2014



CC BY-NC-SA

This work is copyright. Except where otherwise indicated, and save for the Commonwealth Coat of Arms, the Department has applied the Creative Commons Attribution-Noncommercial-Share Alike 3.0 Australia Licence to this work.

The Department of Industry must be attributed as the author of the Department's copyright material.

As far as practicable, material for which the copyright is owned by a third party has been clearly labelled. The Department has made all reasonable efforts to ensure that this material has been reproduced in the print-based resources and accompanying website with the full consent of the copyright owners.

Requests and enquiries concerning the Department's copyright material should be emailed to: media@innovation.gov.au

Questions about the design and content of the resource itself should be addressed to the project manager:

David McElvenny
Workspace Training
PO Box 1954 Strawberry Hills, NSW, 2012
Email: david@workspacetraining.com.au

Disclaimer

The content of this Learner guide is provided for educational purposes only. No claim is made as to the accuracy or authenticity of the content. The views expressed in this publication do not necessarily represent the view of the Minister for Industry or the Australian Government. The Australian Government does not give any warranty nor accept any liability in relation to the contents of this work.

About this resource

This Learner guide is part of a suite of resources developed for the Kitchen and Bathroom Cabinetmaking project, funded by the WELL Program. The resources support 15 competencies from the *Certificate III in Cabinet Making (Kitchens and Bathrooms) (LMF32109)*. The project comprises a website and an accompanying set of Learner guides and Work books.

The project has been completed in two stages. Stage 1 (undertaken in 2011-12) supported 11 competencies and Stage 2 (2013-14) supported a further 4 competencies.

The guides developed under Stage 2 of the project are shown below. Note that one of the 'learning units' contains two competencies clustered together.

Learning unit title	Competencies covered
Communication and teams	<i>MSAPMSUP102A: Communicate in the workplace</i> <i>MSAPMSUP106A: Work in a team</i>
Work documents	<i>LMFGN3001B: Read and interpret work documents</i>
Hand and power tools	<i>LMFFM2001B: Use furniture making sector hand and power tools</i>

The purpose of these resources is to help apprentice kitchen and bathroom cabinetmakers acquire the background knowledge needed to satisfy the theoretical components of the units covered in this project. However, the resources are not designed to replace the practical training necessary to develop the hands-on skills required. Learners will still need to receive extensive on-the-job training and supervision before they will be ready to be formally assessed in the relevant competencies.

E-learning version

All of the content material contained in this Learner guide is also available in an e-learning format, which has additional photos, interactive exercises and a voice-over narration of the text. The e-learning version can be viewed on the web at: www.kbcabinetmaking.com.au

The web version can also be purchased on a CD at a cost-recovery price from the project developer:

Workspace Training
PO Box 1954 Strawberry Hills, NSW, 2012
Email: david@workspacetraining.com.au

Acknowledgements

Project team

Project manager: David McElvenny

Instructional design: Kath Ware

Technical developer (website): Jim Vaughan

Quality assurance consultant: Giselle Mawer

Industry coordinator: Gary Dunshea (MSA Industry Skills Council)

Technical Advisory Group

New South Wales and ACT

Brad Holmes – Hunter TAFE

Dean Brakell – Furnishing Industry Association of Australia

Rob Cole – Furnishing Industry Association of Australia

Warren Peters – South West Sydney Institute of TAFE

Sean Greening – South West Sydney Institute of TAFE

Martin Jud – Canberra Institute of Technology

Victoria

Bryon Stanley – Furnishing Teacher's Advisory Group (VIC, SA, TAS)

Richard Brooks – Cabinet Makers and Designers Association

Simon Hampton – Wodonga TAFE

Leigh Hill – Holmesglen TAFE

Tasmania

Stephen Kirkman – Skills Institute Tasmania

Queensland

Rob McAdam – Skills TECH Australia

Brad Buhse – Skills TECH Australia

Roberto Viola – Gold Coast Institute of TAFE

Lin Parkes – Barrier Reef Institute of TAFE

South Australia

John Holst – Marlestone TAFE

Dean Hart – Mt Gambier TAFE

Martin Videon – Furnishing Industry Association of Australia

Northern Territory

Hermann Oltrop – Charles Darwin University

Western Australia

Garry Michels – Polytechnic West

Keith Campbell – Polytechnic West

Adrian Boyling – Polytechnic West

David Boaden – Polytechnic West

Lorenzo Procopio – South West Institute of Technology

Content material

The content material has been drawn from training notes provided by the reviewers and advisors listed above, plus the following publications:

ANTA, ABC and TAFE learner guides

Photographs and graphics

Photos were taken by David McElvenny.

Graphics were drawn by Kath Ware.

Financial contributions

This resource was funded by the Workplace English Language and Literacy Program by the Australian Government through the Department of Industry. Additional financial assistance was provided by Manufacturing Skills Australia (Industry Skills Council).

Table of contents

Introduction	1
Section 1 Types of tools	3
Overview	5
Measuring and setting out.....	7
Hammering and nailing	10
Drilling and screwing.....	12
Planing and sanding	14
Cutting, chiselling and routing.....	17
Storage and maintenance.....	20
Sharpening cutting edges	23
Assignment 1	27
Section 2 Power sources.....	29
Overview	31
Electricity	32
Compressed air.....	36
Other power sources.....	40
Assignment 2	42
Section 3 Safe operating procedures	43
Overview	45
General safety.....	46
Drill operation.....	48
Jigsaw operation.....	50

Planer operation.....	51
Circular saw operation	53
Nail gun operation.....	55
Assignment 3	57
Practical demonstrations	58

Introduction

Hand-held tools are like extensions to your own body.

They allow you to 'feel' the material you're working with and monitor the performance of the tool through sensations such as resistance to movement, changes in smoothness, and the pull in one direction or another.

This unit will provide you with an overview of the hand and power tools used by kitchen and bathroom cabinetmakers and the safe operating procedures that apply to using power tools.



Note that we won't go into detail on how to use some of the more traditional woodworking tools, such as spoke shaves, hand planes and rasps. These techniques will be covered in other units from your cabinetmaking trade course that deal with joining and shaping solid timber furniture components. However, we will look briefly at the wide range of tools used by cabinetmakers in the first section of this unit.

Working through this unit



There are three sections in this unit:

- *Types of tools*
- *Power sources*
- *Safe operating procedures.*

Each section contains an *Overview*, an *Assignment* and *Lessons* which cover the content material.

Assignments

Your trainer may ask you to submit the assignments as part of your assessment evidence for the unit. You will find hard-copy templates for these assignments in the separate Workbook.

Electronic 'Word' templates of the assignments are available on the website for this resource, at: www.kbcabinetmaking.com.au

Learning activities

Each of the lessons has a learning activity at the end. The Workbook for this unit contains all of the learning activities together with spaces for written answers.

Again, you will find the learning activities on the website version, together with some interactive 'Just for fun' exercises.

Practical demonstrations

Your final assessment of competency in this unit will include various practical demonstrations. Their purpose is to assess your ability to use hand and power tools in a range of situations. To help you get ready for these assessment activities, see the sample checklist shown in the *Practical demonstrations* section at the back of this Learner guide.

Section 1

Types of tools



Overview

There's a huge variety of hand and power tools available to cabinetmakers, often with different designs for each type of tool.

Sometimes you can get away with using a tool that isn't quite right, but gets the job done anyway.

However, it's always best to make the effort to get the exact tool you need, especially if you're doing a certain job over and over again.

The right tool for the job not only makes it easier and quicker to get the task done properly, it also greatly reduces the chance of something going wrong or someone getting hurt.



In this section, we'll look at the hand-held tools commonly used by cabinetmakers. As a kitchen and bathroom specialist, you may not need all of these tools, particularly if you only work with manufactured board products. But it's still important to know what the full range of tools are, because there may be times when you come across a tricky situation that is best handled with a specialised tool.

We'll also cover the basic set-out and measuring tools used on-site for installing kitchen and bathroom cabinets.

Completing this section



The assignment for this section will ask you to describe a range of hand tools that you use at work. Have a look at *Assignment 1* on page 27 to see what you'll need to do to complete it.

There are seven lessons in this section:

- *Measuring and setting out*
- *Hammering and nailing*
- *Drilling and screwing*
- *Planing and sanding*

- *Cutting, chiselling and routing*
- *Storage and maintenance*
- *Sharpening cutting edges.*

These lessons will provide you with background information relevant to the assignment.

Measuring and setting out

Cabinetmakers use a variety of measuring and setting-out tools when they're making cabinets in the workshop.



Some of these tools, like tape measures and squares, are also used on-site when the units are being installed.

There are various other tools you can also use on-site to measure lengths, check levels and mark set-out lines.

Below are the main items used in the workshop and on-site for these purposes.

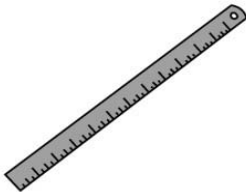
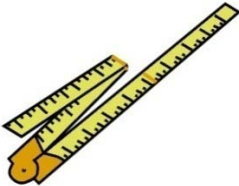
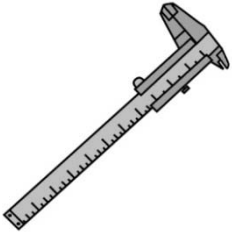

Measuring lengths and dimensions



 <p>Tape measure – for general measuring tasks, such as marking lines, checking dimensions and site measure-ups.</p>	 <p>Steel rule – very rugged, good for fine measurements, also able to be used as a straight edge.</p>	 <p>Folding rule – not so popular these days, but still sometimes used by carpenters.</p>
 <p>Vernier caliper – used for measuring thicknesses and diameters very precisely.</p>	 <p>Laser distance meter – measures lengths digitally with a laser beam.</p>	

Setting out angles

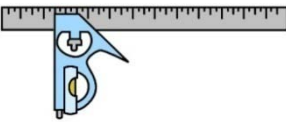
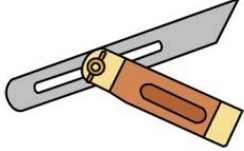
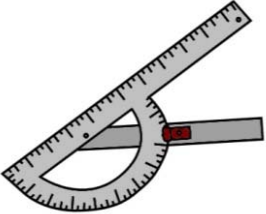
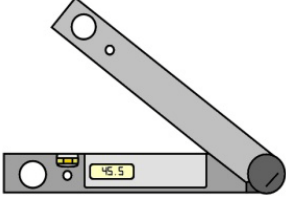
The most common hand-held tools used to set out angles are:

 <p>Carpenter's square – used to draw or check right angles, and also to set out other angles.</p>	 <p>Combination square – allows you to set out 90° and 45° angles.</p>	 <p>Bevel – lets you set any angle you like.</p>
 <p>Protractor – like a bevel, but has the degrees marked in an arc.</p>	 <p>Electronic angle finder – provides a digital readout of the angle formed by the arms.</p>	

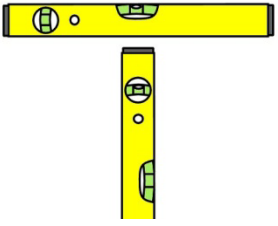
Checking and marking levels

 <p>Spirit level – uses a bubble to show whether a line or surface is level (perfectly horizontal) or plumb (perfectly vertical).</p>	 <p>Laser level – for projecting level and plumb lines on walls.</p>
---	---

Checking and marking straight lines

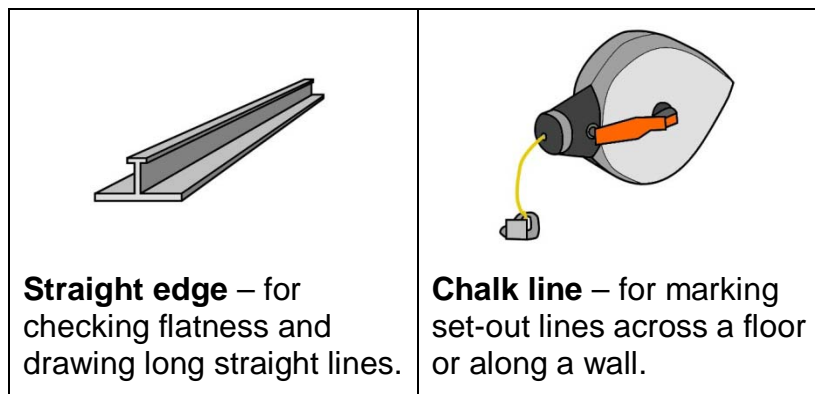

Learning activity



Are there any tools shown above that you don't use in your work as a kitchen and bathroom cabinetmaker? Write them down in your workbook.

Are there other tools that you do use for measuring or setting out that aren't shown here?

Write down their names, and briefly describe what they're used for.

Hammering and nailing

Cabinetmakers have a range of hammers and mallets to choose from when they need to insert a fastener, tap something into position, or use with a chisel.

There are also various power tools that can be used for some of these tasks, particularly for driving in nails and staples.

Below is the general range of hammers, mallets and nail and staple guns.



Hammers and mallets

 <p>Claw hammer – has a flat head on one side for driving nails and tapping items, and a claw on the other side for withdrawing nails.</p>	 <p>Warrington hammer – has a standard flat head on one side, and a 'cross pein' on the other side to start a small nail or brad without hitting your fingers.</p>
 <p>Ball pein hammer – has a standard flat head on one side and a 'ball pein' on the other, used for beating metal and other functions.</p>	 <p>Mallet – for tapping woodworking chisels.</p>

Nail guns and staple guns

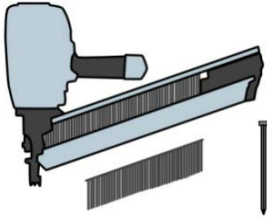
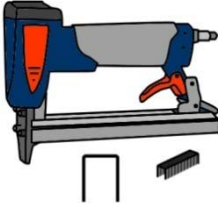
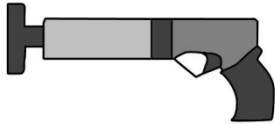
 <p>Nail gun – used to fire nails into timber and wood-based panels, such as particleboard, plywood and MDF.</p>	 <p>Staple gun – used to fire staples, particularly when fixing panels to the backs of cabinets.</p>	 <p>Powder actuated gun (e.g. 'Hilti' and 'Ramset' gun) – used to fire fasteners into concrete and steel with an explosive charge.</p>
--	--	--

Learning activity



What sorts of hammers do you use at work?

Name each type of hammer, mallet or gun, and briefly describe what tasks you use it for.

Drilling and screwing

Modern kitchen and bathroom cabinet construction involves a lot of drilling and fastening with screws.

In the workshop, most of the holes are produced by static machines while the components are being manufactured.

But out at the jobsite, you'll have to drill all of the holes yourself with a hand-held drill.



You'll also use a cordless drill constantly to insert screws. And for more delicate jobs and adjustments of hardware items, you'll need a set of screwdrivers. Below are the main items of equipment used for drilling and screwing.

Screwdrivers

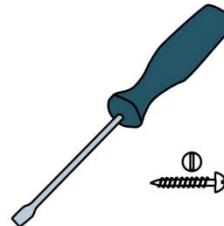
 <p>Phillips head screwdriver – for inserting and removing screws, and turning adjustment screws that have a Phillips head.</p>	 <p>Flat head screwdriver – for inserting and removing screws, and turning adjustment screws that have a 'slot' head.</p>
---	--

Electric drills

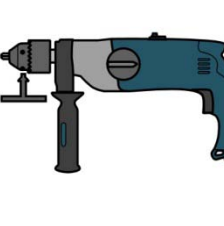
 <p>Cordless drill – for use as a powered Phillips head screwdriver, and for drilling small holes.</p>	 <p>Hammer drill – for drilling larger holes on the 'normal' setting and drilling holes in masonry on the 'hammer' setting.</p>
--	--

Learning activity



The most common screw heads you're likely to come across are Phillips and slot head. But there are other types of screw heads.

Can you name any of these more specialised screw heads?

Write down the names in your workbook. For each one you identify, provide a brief description of where that type of screw is used.

Planing and sanding

Hand planes have been used for centuries by woodworkers to remove surface layers of timber.

There are many specialised variations of the hand plane, including spoke shaves and cabinet scrapers, although these are rarely used by kitchen and bathroom cabinetmakers.



These days, you're much more likely to use an electric plane for planing solid timber and wood-based panels, and a sander for smoothing timber surfaces.



Nonetheless, there may still be times when you'll find that a hand plane is the best tool for a tricky job – like the fellow shown in the photo on the Introduction page of this unit. You might also use a block and sandpaper for small touch-up jobs, and a rasp or file to finish off edges, particularly on veneered or melamine faced boards.

Set out below are the main tools used for planing, sanding, filing and rasping. Some of these, such as the spokeshave and scraper, will only be found in a traditional cabinetmaker's toolkit, but they are still used by some specialist craftspeople.

Planing tools

 <p>Electric planer – for removing surface material from solid timber and panel products with rotating cutters.</p>	 <p>Hand plane – for removing surface material by pushing the blade along the surface by hand.</p>	 <p>Spokeshave – for shaping round or curved components (traditionally used for shaping wooden wheel spokes).</p>
---	--	---

Sanding

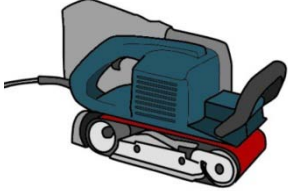
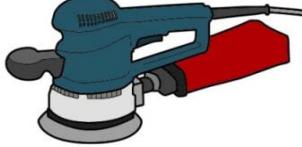
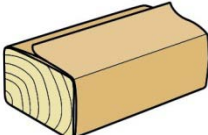
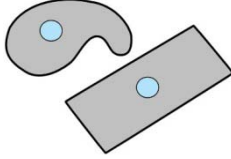
 <p>Belt sander – for sanding timber surfaces with a sanding belt.</p>	 <p>Orbital sander – for use when a belt sander is too awkward, or a finer finish is required.</p>
 <p>Sandpaper and block – for touching up small areas or sanding puttied nail holes by hand.</p>	 <p>Scraper – for finishing benchtops and other high quality timber surfaces by scraping the surface rather than sanding it.</p>

Rasps and files

 <p>Rasp – for shaping wood, such as rounding the corners of timber benchtops.</p>	 <p>Rasp plane – a heavy duty rasp that's used with a plane action.</p>	 <p>File – for removing burrs and overhangs in timber, metal, plastic and composite materials.</p>
--	---	--

Learning activity



Sandpaper comes in a variety of 'grit' sizes, using numbers to refer to the coarseness of the abrading material.

Coarser grits are used when you need to remove a lot of material quickly. Finer grits are used when you're finishing off the surface in preparation for a paint or clear coating.

Do you know what some of the common grit sizes are for different grades of sandpaper? Write down a typical coarse, medium and fine grit size that might be used for sanding a timber benchtop.

Cutting, chiselling and routing

Some tools use a saw blade with teeth to cut materials. The blade could be circular or straight, depending on the cutting action of the tool.

Other tools use a wide flat blade with a sharp edge to do the cutting. These include knives and chisels.

A router is in between, with a small circular router bit that has a rotating cutting action.



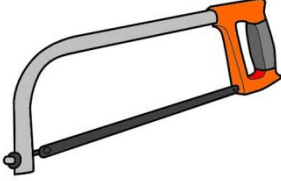

Set out below are the main types of saws, chisels and routers you'll come across in your kitchen and bathroom work.

Hand-powered saws



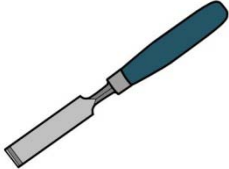

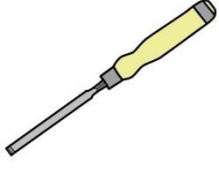
 <p>Handsaw – for cutting timber and wood-based panels.</p>	 <p>Hacksaw – for cutting metal, plastic and composite materials.</p>
---	--

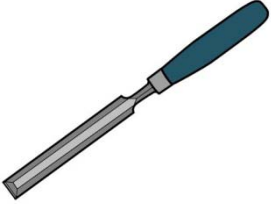
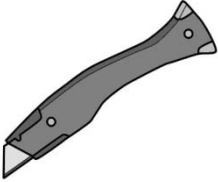
Chisels and knives

 <p>Firmer chisel – for general purpose use, suitable for tapping with a hammer or mallet.</p>	 <p>Bevelled edge chisel – also for general work, but better for getting into corners because of the bevelled edges.</p>	 <p>Mortise chisel – for chopping mortises (recesses) with a mallet and levering out material.</p>
--	--	--

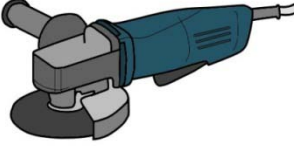
 <p>Paring chisel – for ‘paring’ back the surface of timber and panel products by hand.</p>	 <p>Utility knife – for trimming melamine edges, glue lines and general cutting work.</p>
---	---

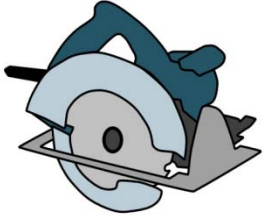
Power tools

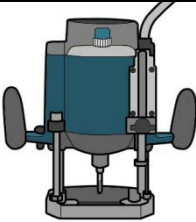
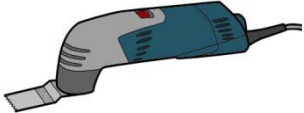
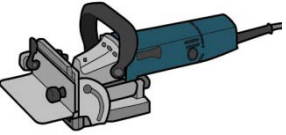
 <p>Angle grinder – for cutting and grinding masonry and steel.</p>	 <p>Jigsaw – for cutting panels and timber to a profiled shape.</p>	 <p>Circular saw – for cutting straight lines in timber and panels.</p>
 <p>Drop saw – for cross-cutting timber and board products to length.</p>	 <p>Router – for cutting grooves and rebates in timber and board products.</p>	 <p>Multi tool – for cutting under door jambs and in other awkward areas.</p>
 <p>Biscuit joiner – for cutting slots in the edges of material to be joined with ‘biscuits’.</p>		

Learning activity



We've said above that a router is designed to cut grooves and rebates. What's the difference between a groove and a rebate?

Go to your workbook and do a simple line drawing of each one. Put a label under each drawing.

We've also said that a biscuit joiner is used to cut slots (known as 'mouths') in the corresponding edges of two pieces of material that are to be joined together.

Do you know what a biscuit looks like? Draw one in your workbook and label it. If you haven't seen one before, ask your trainer for more information, or look it up on the web.

Storage and maintenance

Professional installers need to be able to rely on their tools when they're out at a jobsite.

Missing attachments, blunt blades or malfunctioning parts can be very disruptive to an efficient installation, and very frustrating to the installer – not to mention other team members who might be left waiting.

The good news is that most of these problems are entirely avoidable if you look after your tools and carry spare parts with you.

It's also important to buy high quality tools and replacement parts, so you can have the confidence that they'll do the job you expect of them each time you pick up the tool.

Below are some general suggestions on looking after tools and equipment.

General hints



Don't leave tools lying around on the floor. Put them back in your toolbox or in a designated area when you've finished using them.

This will not only keep them away from dust and sources of damage, it will also reduce the chance of someone else packing them up into their own toolbox.

Protect the cutting edges of saws, chisels, and other cutting tools.

Lay hand planes on their side and put plastic caps on chisel blades when you've finished using them.





Keep delicate tools in their own bag or carry case.

Sensitive measuring devices and other tools that could be affected by dust or moisture should only be left out while you're actually using them.

Store loose items and spare parts in their own containers.

These may include blades, bolts, screws, pin heads, probes and specialised attachments.

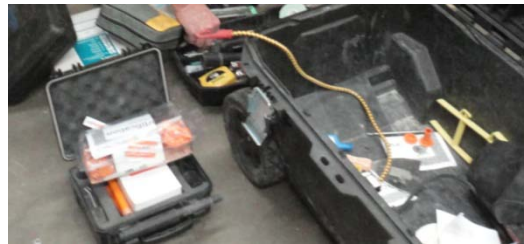

Lubricate moving parts and clean out any excess dust as required.

Don't wait until parts start to seize up or air filters get blocked. The manufacturer's manual for each tool will have a checklist and a recommended schedule for carrying out general maintenance procedures.

Put a tag on any tools that are malfunctioning.

This especially applies to power tools. The tag could say 'Do not use' or 'For repair' or something like that.

Then take the tool to your supervisor or an authorised maintenance person so they can attend to the problem.

Never put faulty power tools away for someone else to pick up and use – at the very least it will be annoying for them when they find the tool doesn't work, and at worst it could be very dangerous.



Learning activity



Do you have responsibility for carrying out any specific maintenance procedures on the tools you use at work?

For example, your job might include being responsible for cleaning out vacuum cleaners and filters, or replacing blunt blades on cutting tools, or doing routine maintenance on machines that need to be oiled or cleaned.

List each tool that you are personally responsible for and briefly state what sort of maintenance procedures you carry out.

Sharpening cutting edges

Cutting edges don't stay sharp forever.

In fact, tools that are designed to be razor sharp – such as knives and chisels – tend to go blunt very quickly while you're using them, especially if you're cutting hard materials.

In the case of utility knives, you can simply replace the blade once the edge goes dull.

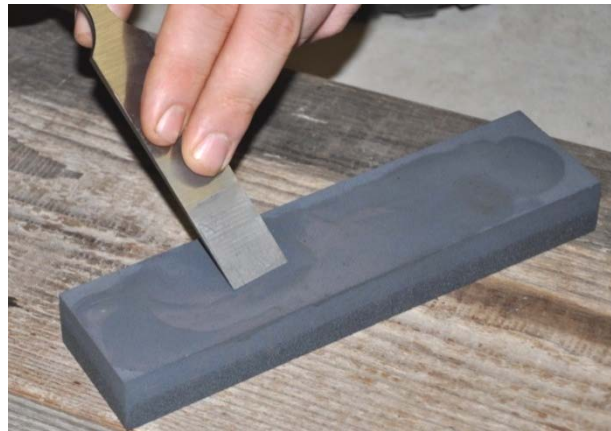

But chisels need to be rubbed up on an oilstone – or 'honed' – regularly. In some cases you may need to do this several times in a single work session. The same applies to the blade (called the 'iron') in a hand plane. Some tradespeople also like to sharpen their own electric planer cutters. But many people find it easier to send them to a professional sharpening service, or simply replace them with a new set.

Note that plywood and particleboard will dull sharp blades more quickly than solid timber, because the glue in these manufactured boards is harder than the wood fibres.

Below is the general procedure for sharpening chisels. The same process applies to hand plane irons. Also below are some hints on how to sharpen drill bits, since they too will need touching up from time to time.

Chisels

There are two important angles at the sharp end of a chisel – the grinding angle and the sharpening angle.

The **grinding angle** is formed on a grinding wheel. It should be between 25° to 30° from the face of the chisel blade.

The **sharpening angle** is between 30° to 35°. This is the angle that gives you a sharp cutting edge, so it's the one you must maintain by 'honing' the chisel regularly on an oilstone.

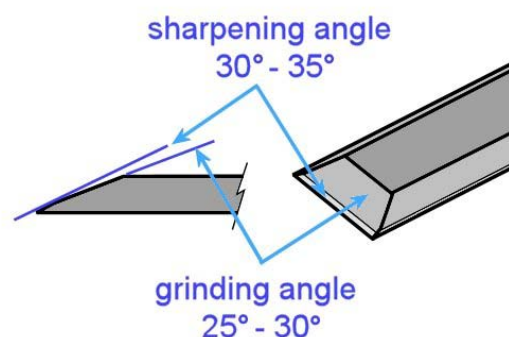

If you're cutting softwood or doing very delicate work, keep the angle closer to 30°, because that will give you a sharper blade. But for harder materials, an angle closer to 35° is better, because the edge is less brittle, so it's less likely to break away while you're cutting.

Honing

Here's how to hone a chisel:

1. Spread a small amount of oil on an oilstone.
2. Put the back of the chisel blade flat on the stone and rub it back and forth to clean it and take out any burrs.
3. Turn the chisel over and raise it to the point where the grinding surface is flat against the surface of the stone.

Then lift the chisel up slightly further to find the sharpening angle.

4. Rub the chisel in a figure-eight pattern on the stone to hone it.

A tiny burr will form on the back of the blade at the edge, called a 'wire edge'.

5. Turn the blade over and hold the back flat against the stone.

Rub the blade back and forth to remove the wire edge.

6. If the blade is not sharp or the wire edge has not fully come away, repeat steps 3 and 4, using a few strokes only, until you achieve a sharp edge.

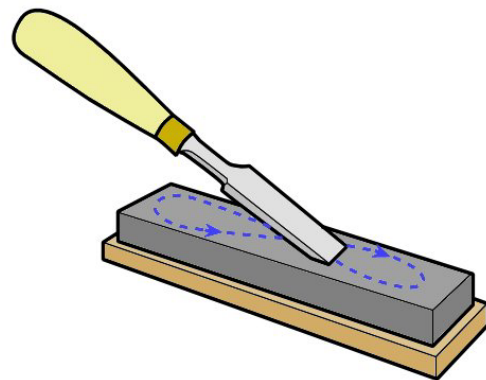
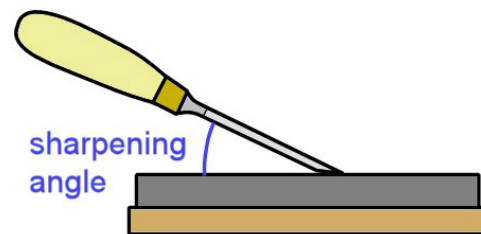
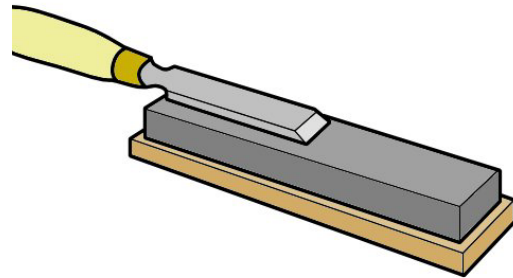

Grinding



After repeated sharpenings, the angle of the sharpening bevel will start to increase as the end gets progressively shorter. Eventually, you'll need to regrind the chisel to get back to a full-length 25° flat surface.

When you're grinding the chisel, be very careful to avoid overheating the edge, because this will cause the steel to lose its strength or 'temper'. Cool the edge frequently by dipping it in water.

The video clips referenced in the learning activity below shows the procedures used to grind and hone a chisel.

Drill bits

Like chisels, drill bits will lose their edge at different rates, depending on what materials you're working with. Metals, manufactured boards and surface laminates will all take their toll on the cutting edges of a drill bit.

There are various machines and jigs designed for sharpening drill bits. Some of these are quite cheap and available in any hardware store. But many tradespeople like to sharpen their own drill bits by hand, using either a grinding wheel or hand file.

The equipment and technique you use will depend on the type of drill bit you're sharpening.

For kitchen and bathroom cabinetmaking, you'll probably use a twist drill most of the time for small holes and a spade bit for larger ones. There may also be times when you use an auger or brad point.

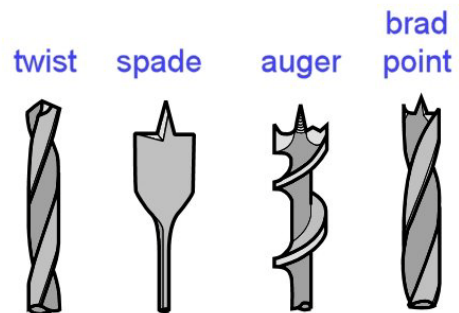

Follow the links in the learning activity below for more information on how to sharpen each of these types of drill bits.

Learning activity



Below are some links to web pages and YouTube video clips showing how to sharpen chisels and drill bits. We'll concentrate on the procedures used to hone a chisel on an oilstone and grind a twist drill on a bench grinder. These are the two skills you're most likely to use in your day-to-day work.

Also below are references to web pages and video clips showing other procedures relating to sharpening chisels and drill bits. These are for your own general interest. You'll find many other video clips on YouTube – just type in phrases like: 'How to sharpen a wood chisel', or 'How to sharpen a drill bit'.

Honing a chisel on an oilstone

<http://www.youtube.com/watch?v=1F5aSs2ureQ>

Watch the video clip and then answer the following questions:

- What sharpening angle does the demonstrator use for his honing?
- How does he remove the wire edge?

Sharpening a twist drill

<http://woodgears.ca/drill/sharpen.html>

Have a look at the photos and read the text beside each photo. Then scroll down to the video clip and watch it. Answer the following question:

- What is wrong with 'sweeping the edge too far back' when you turn the drill bit while grinding it on the grinding wheel? That is, what will it do to the cutting edge?

More information

For a demonstration on how to grind a chisel on a bench grinder, go to:

<http://www.youtube.com/watch?v=3Hm4HiN2Lww>

For details on how to sharpen auger, spade and brad point bits, go to:

http://workshopcompanion.com/KnowHow/Tools/Sharpening/9_Sharpener_Drill_Bits/9_Sharpener_Drill_Bits.htm

Assignment 1

Choose three hand tools you use at work that don't require a power source other than your own muscles. (Note that we will cover power-operated tools separately in Assignment 3.)

For each tool, provide the following information:

1. What type of tool is it?
2. Who is the manufacturer and what is the brand name of the tool?
3. What is its main purpose?
4. What secondary functions does the tool have (if any)? That is, does the tool have any other features, attachments or uses?
5. What personal protective equipment should you wear when you are using the tool (if any)? For example, do you need to wear safety glasses, gloves, dust mask, etc. If you only need to wear PPE for certain types of jobs, state the item of PPE and briefly describe when it would be required.
6. Does the tool have any fragile or delicate parts that need to be protected? If so, how do you protect them, and how do you carry the tool to the jobsite?
7. Does the tool have any parts that are designed to wear out and be replaced on a regular basis? For example, you may need to carry spare blades, cutters, tips, etc. What are these replacement parts, and how do you carry them with you to the jobsite?
8. Do you need to carry any other equipment or maintenance item to the site to keep the tool operational? For example, do you need to have a sharpening stone, oil, grease or other item in your toolbox to keep it working properly?
9. What checks do you need to carry out before you use the tool? These may include safety checks, adjustments, inspections on the sharpness of blades, tightening of screws, etc.
10. What are the main things that can go wrong with the tool? For each problem you state, briefly describe how you would fix it, or whether the problem would mean that the tool must be put in for repair or thrown out.

Section 2

Power sources



Overview

Hand-held tools use a wide range of energy sources.

The most common forms of energy are mains electricity, rechargeable battery, and of course, good old fashioned muscle power.

However, there are times when other power sources are used – generally because you're either using a specialised tool or you're on-site and the mains power hasn't yet been connected.



In this section, we'll look at the main types of energy used to drive hand-held power tools. We won't go into muscle power, because the issues relating to 'manual handling' and physical exertion have already been covered in other units.

Completing this section



The assignment for this section will ask you to compare two tools that are powered by different energy sources, but are designed to do the same job.

Have a look at *Assignment 2* on page 42 to see what you'll need to do to complete it.

There are also three lessons in this section:

- *Electricity*
- *Compressed air*
- *Other power sources.*

These lessons will provide you with background information relevant to the assignment.

Electricity

The two most common sources of electricity for power tools are mains electricity and rechargeable battery.

Note that heavy industrial machines generally run on 415 volt power, also called 'three-phase' power.

However, they use a different type of power plug and socket and are not produced in the hand-held range of power tools.



Mains electricity



Some people refer to mains electricity as '240 volt power', because that's the voltage that comes out of a standard power point.

Standard power points are designed to take two-pin or three-pin plugs. One pin connects to the **active** or live wire. The opposing pin connects to the **neutral** wire, which completes the circuit.

The bottom pin has no role in delivering electricity, but connects the tool to the **earth** wire as a safety mechanism, in case there is a malfunction or 'short circuit'.

Power circuits are always protected either by a fuse or circuit breaker. If the system is overloaded or a fault develops, the fuse is designed to blow, or the circuit breaker to trip, which cuts off the power supply.

There are two main systems of insulation used in power tools:

- **Single insulated tools** use an earth wire which is connected to the metal casing of the tool at one end and the earth pin of the plug at the other end. In the event of a fault that causes a short circuit, the current is able to flow straight to earth without giving the operator an electric shock.
- **Double insulated tools** use two layers of insulation between the internal parts that carry a current and the outer metal parts of the body. For this reason, they are not connected to an earth wire.

Rechargeable battery

As rechargeable batteries continue to improve in performance and power output, an increasing variety of 'cordless' tools are coming onto the market, including jigsaws, circular saws, planers, and even chainsaws.

However, by far the most common cordless power tool is the drill. This is because most drills are smaller and consume less power than the other types of tools, so their rechargeable batteries are lightweight and relatively cheap.



Always remember to pack the battery charger when you take cordless tools to the jobsite. It's also a good idea to take two batteries, so you can leave one on 'charge' while the other is in the tool.

Safety with mains power

Mains power is used everywhere, but that doesn't mean you should take its safety for granted. Every year people are hospitalised as a result of electric shock, and occasionally the shocks prove fatal.



Electrical faults are also responsible for many fires, because the sparks from short circuits or the heat from overloaded wires can ignite flammable substances or materials.

The first rule when using power tools is to make sure the electrical cable is in good condition.

Check that the insulation is sound and there are no exposed wires at the plug end or the other end where it enters the tool.

The second rule is to avoid using electrical tools in wet conditions. If it has been raining, or you're in a wet area, only use the tool if:

- your hands are dry
- the tool is completely dry
- you are wearing rubber soled boots and standing on a dry surface
- electrical leads and connections are clear of damp ground.

Testing and tagging

It is a WorkCover requirement that all power tools used at work are **tested and tagged** every three months by an authorised person. The test is designed to ensure that the tools are safe and not likely to cause a fire or electric shock.

Once a piece of equipment has been tested and passed, the authorised person attaches a tag to it, stating their name or company they work for and the test date.

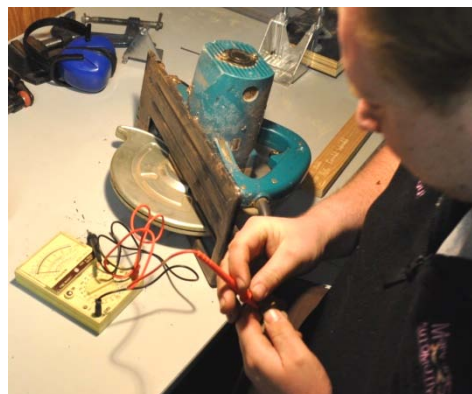

If you pick up a power tool and find that the tag is out of date, make sure you take it straight to the person responsible for getting it tested.

Setting up extension leads

If the power source is not close to the area you're working in, you may need to run an extension lead some distance. Always make the effort to keep extension leads safe, because they can be a serious hazard to your own team as well as other workers on-site if you don't.

Here's some tips on using extension leads safely:

- Fully unwind a long lead before you use it. Leads that are left coiled up can generate a lot of heat when there's a current passing through them.
- Check the plugs at each end to make sure that the wires aren't starting to pull out. If the plugs or lead are not in good condition, tag it and take it straight back to your supervisor for repairs.
- Never pull a plug out of a socket by tugging on the lead. Always hold the body of the plug when you remove it.
- Keep leads clear of wet patches on the ground or floor. This especially applies to any joins in leads.
- As a rule of thumb, use leads rated at a minimum of 10 amps for power tools, and 15 amps or more for large machines.



- Try to keep the lead as short as possible for the job you're doing. The longer a lead is, the higher the voltage drop will be from one end to the other, so the higher its amp rating will need to be.
- Don't drape leads across walkways, access-ways or vehicle paths. If there is no alternative to running a lead across a thoroughfare, make sure the lead is very obvious, and either protect it from vehicle and pedestrian traffic or put it overhead.

Learning activity



Write up a list of the hand-held electric tools you regularly use, naming their brand and power source (mains power or battery).

Also state the size of the tool if you know it. Note that the size is generally expressed in terms of the attachment that does the actual work – such as blade diameter, cutter length or drill bit diameter.

Here are some examples of how the size might be described:

Drill:	10 mm (3/8 inch)	referring to the maximum diameter drill bit that can be put into the chuck
Circular saw:	115 mm (4 1/2 inch)	the diameter of the blade
Electric planer:	75 mm (3 inch)	the width of the cutters

Compressed air

Workshops and factories commonly use compressed air to drive power tools.

For the on-site installer, it's less convenient because you need to take your own compressor with you, which in turn would still have to be powered by an electric, petrol or diesel motor.

However, it is a very useful power source when you're using a gun for nailing, stapling or spraying.



It's also handy when the jobsite doesn't have mains power connected and you already own a petrol-operated compressor.



Tools driven by compressed air are called **pneumatic tools**.

They tend to be more efficient and lighter than equivalent tools powered by mains electricity, because they do away with the need for an electric motor inside the tool.

The compressor itself has a pump which compresses air from the atmosphere.

A receiver, or storage tank, holds the compressed air, and an automatic pressure regulator keeps it at the correct pressure by switching the pump on and off.

If the pressure gets too high, air is released through a safety valve.

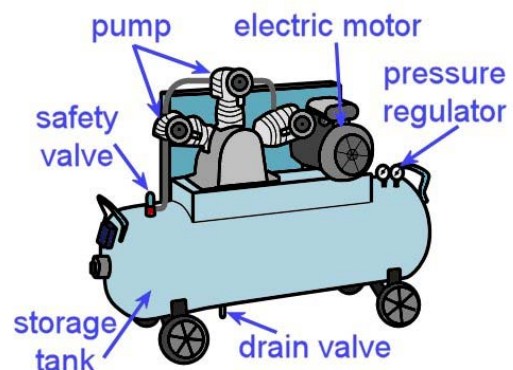

Air supply

The volume of air that a compressor can supply is called **free air delivery**, and is generally measured in terms of litres per minute (L/min). This is what determines how many tools can be run at any one time from the compressor and what types of tools it is suitable for.



Another important specification is the **operating pressure range**. This is measured in kilopascals (kPa) or sometimes pounds per square inch (psi).

Different tools operate best at certain pressures, so the operating pressure needs to be checked and re-adjusted if it's found to be incorrect for a particular tool.

It's a good rule to use the minimum pressure required for the tool to operate properly. This will help the compressor to use less power, and there'll be less wear on the tool.

If you're using a nail or staple gun, it will also reduce the chance of the fasteners countersinking too far and damaging the surface of the material you're firing into.

Routine maintenance for air compressors

Depending on the type of air compressor you're using and the tools you're working with, there will be some routine maintenance procedures that should be followed at certain times. Your supervisor will tell you what your specific tasks are, but here are a few typical examples.

- **Air filters** should be cleaned at regular intervals. If the compressor has a filter bowl, it should be drained each day.
- Some tools need to have **oil drops** added directly to the air intake before the hose is connected each day, to lubricate the moving parts inside.
- **Condensation** that has occurred inside the receiver should be drained at least once a week, or more often depending on the operating conditions and model of compressor. Many workplaces open the drain valve at the end of the week and let the receiver drain over the weekend.
- If the compressor uses a petrol or diesel pump, the **oil level** in the motor will need to be checked regularly.
- The **safety valve** should be checked periodically by lifting the plunger, allowing air to escape, and then making sure that it re-seals properly when it's re-seated.



Special safety precautions

Although compressed air is safer than electricity in some respects, it has other hazards that can be just as dangerous. Below are a few safety guidelines you should follow when using compressed air.

- **Always wear safety glasses** when using compressed air. This includes blowing out tools or cleaning down work areas with an air hose.

The air will cause particles to fly in all directions at high speed.

- **Never point a stream of compressed air** directly at anyone's body, particularly bare skin.

Many people have suffered ruptured ear drums, eye injuries, skin blisters and burst blood vessels from either cleaning themselves down with compressed air, or playing practical jokes with it.

- Make sure you **secure the loose end of an air hose** before turning on the air, to stop it from whipping around when it takes up pressure.



Learning activity



Is there an air compressor in the building where you are right now? You might have it on-site with you, or in the college workshop, or at the warehouse where you're working.

If you don't have a compressor nearby, look up a typical example on the web. Choose a size that you would be likely to use at work.

Answer the following questions in your workbook. You should be able to find the answers on the machine itself or in the specifications listed on the website.

If you get stuck on any questions, ask your trainer or supervisor for more information. They may also be able to show you the manufacturer's manual for the machine.

1. What brand is the compressor?
2. What is the cubic capacity of the receiver?
3. Is the pump diesel, petrol or electric?

4. What is the free air delivery rating (in litres per minute)?
5. What type of air filter does it use?

If you're looking at the compressor right now and it's in operation, also answer the following questions:

6. What operating pressure is it set at?
7. How many hoses branch off it?
8. What types of equipment is it running?

Other power sources

Some specialised tools use power sources other than electricity or compressed air.

This particularly applies to nail guns used on-site, which are sometimes powered by an in-built gas canister or a small explosive powder cartridge.

Let's look at each of these specialised items in turn.



Gas-powered guns

Nail guns powered by gas have a combustion chamber that works like a tiny car engine.

When the chamber behind the piston fills with gas and is ignited by a spark plug, the small explosion pushes the piston forward and drives a nail into the material.

In addition to the gas cylinder needed to supply the gas, these types of guns also carry a rechargeable battery to fire the spark plug.

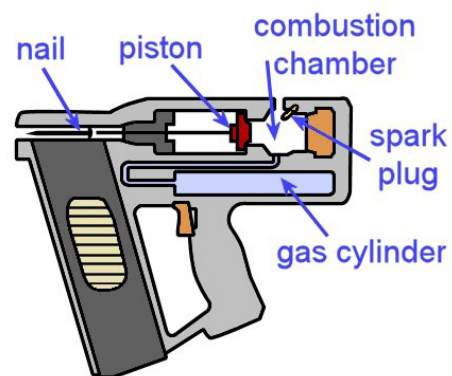

Gas-powered guns have replaced pneumatic guns for many carpenters and other on-site workers, because they don't require an external air compressor. This does away with the problem of having air hoses draped across the work area and causing a trip hazard.

Powder-actuated guns

Powder-actuated (PA) tools are designed to fire fasteners into concrete, steel and other hard materials.

They use the same principle as a firearm, with a small explosive charge placed behind the projectile.

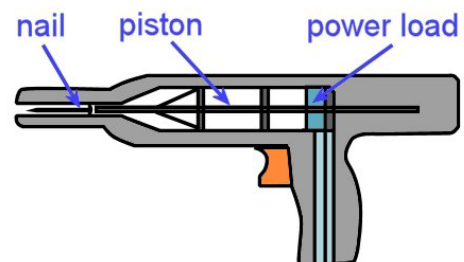

In the case of a PA gun used by a kitchen and bathroom installer, the projectile is most likely to be a hardened steel nail, or 'drive pin'. You might use these nails to fix battens to concrete or brickwork.

Tradespeople generally call powder-actuated tools by their brand name, which is why you'll often hear them called 'Hilti guns' or 'Ramset guns'.

In the past, they were all manufactured as **high velocity** tools, where the explosive charge acts directly on the fastener.

However, more modern versions use a piston to drive the fastener, allowing a more efficient **low velocity** charge to propel the piston.

The high velocity tools are potentially more hazardous than the low velocity ones, and require greater care when you're using them.

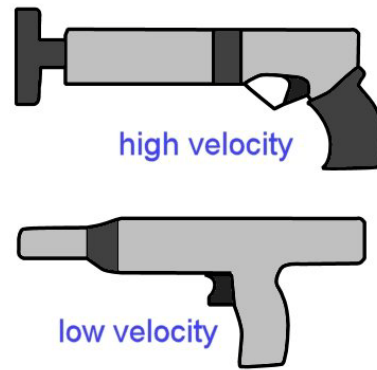

But bear in mind that all powder-actuated guns are potentially dangerous, which is why there are special safety precautions that apply to their use, especially on a jobsite with other workers around. You also need to be properly trained and assessed before you are allowed to use the gun unsupervised.

Learning activity



The following link will take you to a video clip produced by Ramset Australia which describes the difference between high velocity and low velocity powder actuated fasteners. Watch the clip and then answer the questions below.

<http://www.youtube.com/watch?v=MD-yAjSPgwU>

- What is a 'power load'?
- Why is it important to select the correct power load for the material you're fastening into?

To see a more comprehensive 15 minute version of the above video clip, go to the following link:

<http://www.youtube.com/watch?v=2fXgLSHsZNI>

Assignment 2

Choose two power tools from your workplace that both have the same function but are powered by different energy sources. For example, you may have two drills – one running on mains electricity and the other on battery. You might even have a drill that's driven by compressed air.

Answer the following questions:

1. What type of tool are they? State the category of tool your two selections belong to, such as: circular saw, drill, planer, etc.
2. What are the two power sources for these tools? These may include: mains electricity, compressed air, rechargeable battery or gas.
3. Who is the manufacturer (or manufacturers, if they are made by different companies)? That is, what are their brand names?
4. What size is each tool? Describe the size in terms of their drill bit diameter, blade diameter, cutter length, nail length, etc.
5. What are the power ratings? State the power ratings in terms of wattage, operating pressure, etc.
6. What are the main advantages of each tool? List the advantages, particularly in comparison to the other tool you have selected.
7. What are the main disadvantages of each tool? List the main disadvantages, again with particular reference to the other tool.

To get yourself started on the advantages and disadvantages, evaluate the two tools in terms of the following criteria: safety, convenience, portability, overall life expectancy and strength of the tool. Add any other points that you think are relevant.

Section 3

Safe
operating
procedures



Overview

Power tools are generally much faster and more powerful than simple hand tools.

But they have several hazards that don't apply to hand tools, so you need to take extra care when you're using them.

In this section, we'll discuss the safe operating procedures for a range of common power tools.



We'll start with a general summary, and then look individually at some of the tools you're likely to use on-site. Remember, though, that every manufacturer will have their own operating procedures for the tools they produce, so you should always consult the operator's manual for detailed advice on how to use a specific tool.

Completing this section



The assignment for this section will ask you to select three power tools that you use at work and describe their characteristics.

Have a look at *Assignment 3* on page 57 to see what you'll need to do to complete it.

There are also six lessons in this section:

- *General safety*
- *Drill operation*
- *Jigsaw operation*
- *Planer operation*
- *Circular saw operation*
- *Nail gun operation.*

These lessons will provide you with background information relevant to the assignment.

General safety

Set out below are some basic principles for using power tools safely.

Although they can be applied generally to all tools, there are specific references to tools that have a rotary action and are powered by electricity.

This makes these principles particularly applicable to tools such as circular saws, drills and planers.



Basic safety procedures

1. Wear the correct personal protective equipment for the job at hand. This will generally include safety glasses, ear muffs and steel capped boots.

Depending on the job, it might also include a dust mask, gloves and maybe specialised safety gear, such as a full face shield. Remove any loose clothing or jewellery, and tie back long hair.

2. Keep cutting edges sharp. Inspect the saw blade, drill bit or planer cutters before you plug in the tool, and make sure that they are in good condition, properly fitted and sharp.
3. Make sure that the guards are in place and correctly adjusted, and that spring-loaded mechanisms or other moving parts are working normally.
4. Secure the material firmly before you start the job. This could mean using a G-clamp or bench vice or some other clamping system.
5. Always allow the motor to reach normal operating speed before letting the tool come into contact with the job. This helps to avoid the problem of 'kickback', and of overloading the motor.

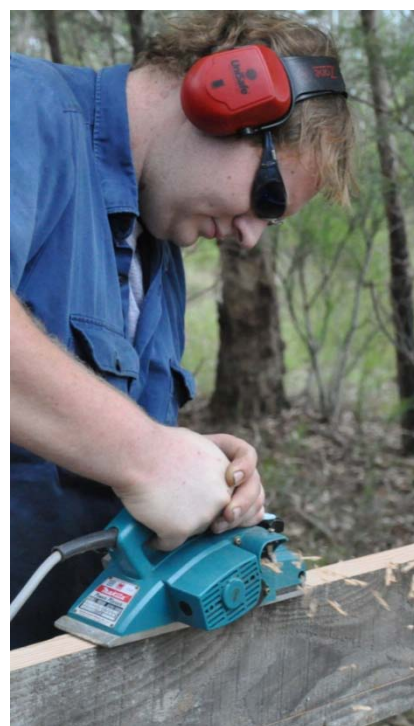

6. Listen to the sound of the motor when you start up the tool and while you're operating it.

If you hear any unusual sounds, stop the tool, unplug it, and look for the problem.

If you can't fix it on the spot, tag the tool and take it to your supervisor or maintenance person for servicing.

7. Keep the work area clear of off-cuts, sawdust and rubbish that might get in the way.



Don't let off-cuts and rubbish build up under your feet. It can pose a serious trip hazard, especially if you're concentrating on the work and not paying attention to where your feet are positioned.

By tidying up as you go, you'll also make the general clean-up at the end of the job much easier. This will help you to sort out which pieces can be recycled or used again and which items need to go straight into the waste bin.

Learning activity



Point 5 above refers to the problem of 'kickback' in power tools. This happens when the blade or cutter is allowed to contact the material to be cut before the motor has had a chance to reach full speed.

What exactly is kickback? See if you can describe it in words.

If you're working with a partner, try to come up with an explanation together. Use your workbook to write down your answer.

Drill operation

Hand-held drills range from small cordless versions to large hammer drills. As a kitchen and bathroom cabinetmaker, there will be times when you'll need both.

A variable-speed cordless drill is best for driving Phillips head screws and drilling small holes in timber and other non-masonry materials.

However, if you're drilling holes in concrete or brick, you'll need to use a hammer drill with a masonry drill bit.

Hammer drills have a 'hammer' and a 'normal' setting. It is possible to buy good quality cordless hammer drills, but in general they're not as powerful as an equivalent-sized 240 volt drill.

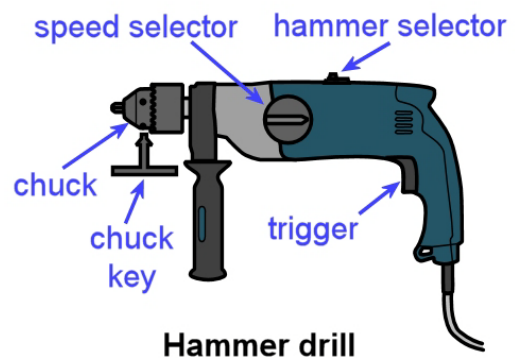
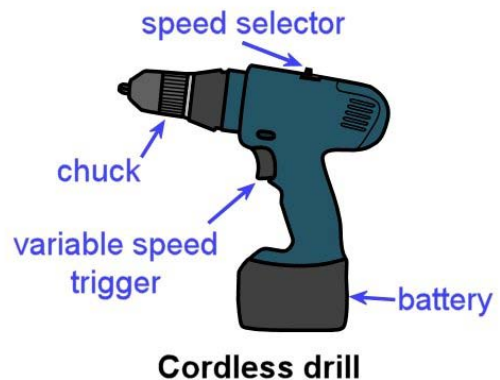

Basic operating procedure

1. Secure the material that needs to be drilled. Insert the drill bit into the chuck and tighten it. If you're using a chuck key, make sure you take the key out before starting the drill.
2. Push the drill bit into the surface of the material. If the material is metal, it's best to centre-punch a small indentation into the surface first, so that the tip of the drill bit doesn't skid off the mark when it starts to turn.
3. Start up the drill and push down firmly. In general, use slower speeds for hard materials.
4. While you're drilling, pull the drill back periodically to clear the waste material from the hole and drill bit. This will help to stop the drill bit from jamming or overheating.
5. On larger drills use both hands to hold the drill, with one hand on the side handle, to avoid the problem of the drill suddenly flicking back in the opposite direction if the bit gets jammed.

-
6. On deep holes, pay constant attention to the angle you're holding the drill at, so you don't start to change the direction of the hole while you're drilling. Keep the drill bit turning until you withdraw it from the hole.

Learning activity



Different types of drill bits are used for drilling different materials and hole sizes.

See if you can name the type of bit used to drill the following holes. Write your answers in your workbook.

- 6 mm hole in a piece of timber
- 32 mm hole in a sheet of plywood
- 12 mm hole in a concrete slab.

If you're not familiar with the drill bits used for these purposes, ask your trainer or supervisor to show you examples. You can also look them up on the web.

Jigsaw operation

Cabinetmakers use jigsaws when they need to cut a profiled or curved shape into a board, such as masonite, plywood, MDF, or timber.

You can also use them to cut aluminium and plastic trims if you fit the correct blade and use the right setting.

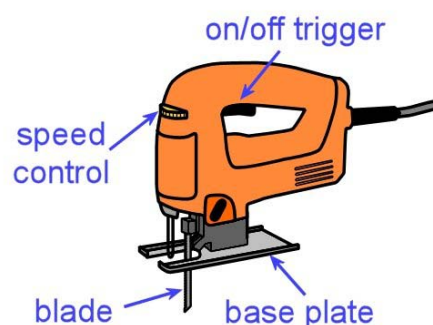

Basic operating procedure

1. Select the correct blade for the material to be cut. Set the saw to the correct speed. In general, higher speeds are used for timber, and lower speeds for metal. Secure the material to be cut.
2. Place the front of the base plate on the material, without the blade touching the work. Check that the base plate is sitting flat on the surface. Start up the saw and let it reach full speed.
3. Begin to cut, keeping the base plate flat on the work at all times. Push the saw smoothly and at a steady pace through the material. Let the saw do the work – don't force the blade through faster than it wants to go.
4. When cutting curves, ease off slightly with pressure and speed to allow the blade to adjust to the changing direction.
5. Finish the cut at full speed and then release the trigger. Allow the blade to stop before putting the saw down.

Learning activity



Jigsaw blades vary in terms of their shape, tooth profile, number of teeth and the type of metal they're made from. The differences are designed to make certain blades more suitable cut cutting particular materials.

Do some research on the different blades available for your own jigsaw, or the one you're using in your training session.

What materials are they designed to cut? Write down the main distinguishing features of the different blades. If you're studying this unit by distance learning, you can also take photos of the blades and match up your descriptions with the photos.

Planer operation

Electric planers are good for reducing the thickness of timber or tapering the width of a panel or bench top.

Note that if you're planing an existing timber floor, always double-check that there are no hidden nails, screws or other hard objects that might hit the cutters. If the cutters strike anything hard while they're turning, it can damage them in an instant.

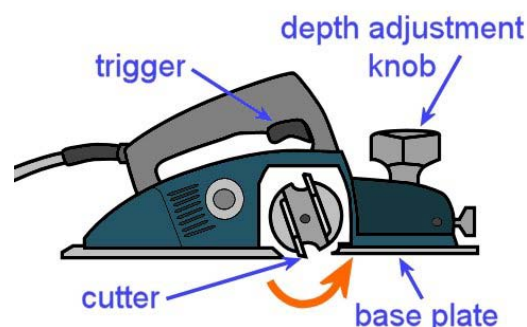

In general, be extremely careful while the planer is running. The cutters are unguarded, and will cut anything that comes into contact with them – timber, floor coverings, clothing, fingers and anything else.

Before you put the planer down, make sure the cutters have stopped turning.

Always disconnect the planer from the power source before clearing out shavings or checking the cutters.

You can either lay it on its side, or put it on a soft material that won't damage the cutters. Remember, the cutters are razor sharp, which makes the edge quite fragile if it is bumped against hard surfaces.

Basic operating procedure

1. Secure the material to be planed so it can't move. Set the cutting depth of the planer by sitting it on the work and adjusting the knob.
2. Position your feet so you're in a comfortable balanced position. Make sure the power lead is out of the way of the planer path. You can put the lead over your shoulder if you think it might get in the way.
3. Rest the front of the base plate on the job and check that it is sitting flat on the surface. Keep the cutters clear of the work – check that they're clear by sliding the planer forward until you feel the cutters touch the work, and then pulling it back slightly.

4. Start the planer and allow it to reach full speed before commencing the cut.
5. Push the planer smoothly forward with an even motion, in the direction of the grain. Be particularly careful to hold the planer flat against the work at the start and finish of the cut and not let it dip at either end.
6. At the end of each sweep along the material, lift the planer off the work before you take your finger off the trigger.

If you're planing the end grain of timber, it's best to work from both sides to avoid chip-out of the grain. This includes the underside of doors, which often have vertical 'stiles' on each side and a 'bottom rail' in between.

Learning activity



Point 5 above says you should plane in the direction of the grain. Note that this applies to solid timber, such as the tongue and grooved timber floor boards. It's not an issue when you're planing particleboard, plywood, MDF or other materials that don't have a distinctive grain direction.

What would happen if you planed solid timber against the grain? That is, what would the finished surface look like?

Circular saw operation

Hand-held circular saws are generally simply called 'power saws'.

They are used to cross-cut timber, rip timber lengthwise and cut wood-based panel products.

Note that they are only designed to cut in a straight line – if you need to cut a profiled shape, such as around a doorjamb or architrave, you should use a jigsaw.

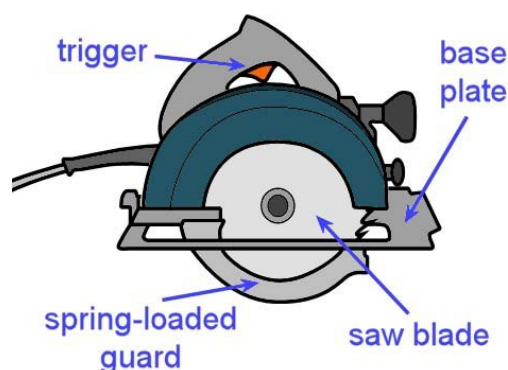

Most power saws run on mains electricity. However, it is possible to buy good quality cordless saws, although they are less powerful than an equivalent-sized 240 volt saw. You can also buy air-operated saws, but they are not as convenient for on-site use.

Like electric planers, circular saws have extra hazards because they're designed to cut at high speed. So many of the same precautions apply, including always being sure that the tool is disconnected from the power source before you check the blade, clear jams or make adjustments.



Unlike an electric planer, you don't need to wait until the saw has stopped turning before you put it down, because the spring-loaded guard will flick back into place when you remove the saw from the work.

But this means you have an additional safety check to carry out – always make sure the guard is moving freely and springing back to its correct position before connecting the saw to the power supply.

Basic operating procedure

1. Secure the material to be cut so it can't move. Draw a line to mark the cut. If the off-cut that will be produced is large or heavy, check that it is well supported so it can't fall or pull away and damage the good piece when you finish the cut.

2. Check the saw blade for damaged or blunt teeth. Check that the spring-loaded guard is working properly. Adjust the saw to the required depth and angle. If you're using a straightedge to guide the saw, clamp it into position.
3. Plug the saw into the power supply. Make sure the power lead is clear of the path of the cut – put it over your shoulder if you think it might get in the way. Position your feet so you're in a comfortable balanced position.
4. Rest the front of the base plate on the material to be cut and check that it is sitting flat on the surface. Keep the blade clear of the work.
5. Start the saw and allow it to reach full speed before commencing the cut. Push the saw smoothly forward with an even motion. Make sure the saw stays straight – don't twist the blade in the cut.
6. Keep the saw straight as you leave the cut and don't release the trigger until the blade is clear of the material. Check that the guard has sprung back into place before placing the saw on the floor.

Learning activity



Point 1 above talks about the importance of securing the material you're about to cut, and making sure any large offcuts will be well-supported before you start cutting.

How would you go about securing the following two pieces of work? Write your answers down in your workbook. You can use a drawing for each one to illustrate your answer if you wish.

1. A long length of solid timber skirting board (say 4.8 m long), to be cut in the middle.
2. A 2400 x 1200 sheet of plywood, to be cut back to 1800 x 1200.

Nail gun operation

Nail guns and staple guns are designed to fire fasteners into timber or wood-based products. The most common power sources are compressed air and gas.

Set out below are the basic procedures for using a pneumatic gun.

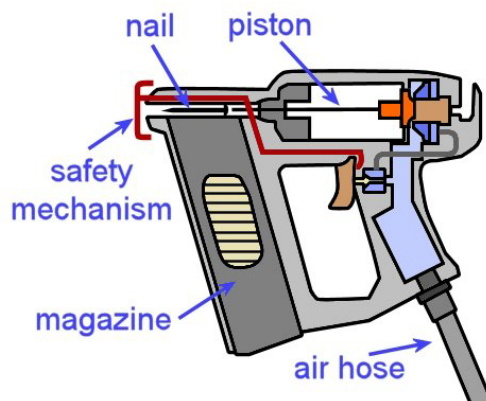

Basic operating procedure

1. Make sure the gun is disconnected from the air supply and check that the moving parts and magazine are free from loose particles, dust build-up and anything else that might cause a jam.
2. Load the magazine with nails or staples.
Connect the air supply to the tool.
3. Push the nose into the work to allow the safety mechanism to depress.
4. Pull the trigger to fire the gun.

In general, keep the following safety considerations in mind whenever you're using a nail or staple gun:

- Always keep your free hand away from the discharge area while you're firing.
- Don't fire fasteners into knots or unsound timber.
- Don't fire fasteners at a sharp angle or too close to edge of the material.
- Never fire towards yourself or in the direction of other people.
- Always disconnect the gun from the air supply before carrying out maintenance, clearing a jam, or handing the gun to another person.



Learning activity



The basic operating procedure described above refers to a trigger action called 'single shot mode'.

In this action, you need to push the nose into the work to let the safety mechanism depress and then pull the trigger to fire the gun. To fire a second nail, you must go through the whole process again.

Some guns have two operating modes – 'single shot' and 'bump fire'. When the bump fire action is selected, you can keep the trigger depressed and simply bump the nose of the gun onto the work each time you want to fire a nail. Bump fire is handy for jobs where you need to fire many nails in quick succession.

What do you think would be the extra safety problems associated with bump fire mode? How would this affect the way you use the gun, or position yourself before you start firing?

Assignment 3

Choose three hand-held power tools you use at work. Do not include either of the tools you selected for Assignment 2. In preference, select tools you will be using for your practical demonstration assessment activities in this unit.

For each tool, answer the following questions:

1. What type of tool is it?
2. Who is the manufacturer and what is the brand name of the tool?
3. What is its main purpose?
4. What personal protective equipment should you wear when you're using the tool? For example, do you need to wear ear muffs, safety glasses, dust mask, etc. If you only need to wear PPE for certain types of jobs, state the item of PPE and briefly describe when it would be required.
5. Specify the attachment or item of hardware on the tool that does the actual work – that is, the drilling, cutting, welding, fastening, heating etc. Preferably, describe the attachments you'll be using for your practical assessment activity, if they are different from the one that's normally fitted to the tool.
6. What checks do you need to carry out before you use the tool? These may include adjustments, calibrations, safety checks, inspections of wear and tear, etc.
7. What routine maintenance procedures are required to keep the tool in good condition? Describe the maintenance procedures, including when they should be carried out, e.g. after each use, weekly, monthly, etc.
8. What are the main problems that would cause you to tag-out the tool and have it discarded or put in for repair? Describe the sorts of things that would make you think the tool was not safe to use. These could relate to unusual sounds, smells, loose parts, damaged parts, etc.

Practical demonstrations

Your trainer may ask you to keep a log book or diary of the work you do on-the-job that relates to the practical components of this unit. This will help them to determine when you've had sufficient hands-on practice in these tasks to undertake the assessment events.

When you're ready to be assessed, your assessor will ask you to complete a range of practical demonstrations. You will be assessed on your ability to:

- use a range of hand-held tools safely and competently
- carry out operator maintenance procedures on the tools you use
- follow all work, health and safety requirements and environmental care procedures
- grind and sharpen chisels, hand plane irons and drill bits
- correctly interpret company documents and work instructions
- minimise waste
- communicate and work effectively with other workers in the area
- prevent damage to goods, equipment and products
- work productively and produce a high quality job
- modify the activities and techniques used to suit different sites and working conditions.

Make sure you talk to your trainer or supervisor about any of the details you don't understand, or aren't ready to demonstrate, before the assessment events are organised. This will give you time to get the hang of the tasks you'll need to perform, so that you'll feel more confident when the time comes to be assessed.