

Adjusting cabinets on-site

KITCHEN AND CABINET BATHROOM MAKING

Supporting:

LMFKB3004A

***Conduct on-site adjustments to
cabinets and components***



Learner guide

Developed in 2011-2012 for the WELL Program

Adjusting cabinets on-site

Learner Guide

This unit is also available in an e-learning format, which contains additional photos, interactive exercises and a voice-over narration of the text. It can be viewed on CD-ROM, or live on the web at:

<http://www.kbcabinetmaking.com.au/>



Developed by Workspace Training for the 2011-2012
Workplace English Language and Literacy (WELL) Program
Kitchen and Bathroom Cabinetmaking resource development project



www.workspacelearning.com.au

ISBN: 978-0-9873328-8-2

Funded under the Workplace English Language and Literacy Program by the Australian Government through the Department of Education, Employment and Workplace Relations.

COPYRIGHT

© Commonwealth of Australia. 2012



CC BY-NC-SA

This work is copyright. Except where otherwise indicated, and save for the Commonwealth Coat of Arms, the Department has applied the Creative Commons Attribution-Noncommercial-Share Alike 3.0 Australia Licence to this work.

The Department of Education, Employment and Workplace Relations must be attributed as the author of the Department's copyright material.

As far as practicable, material for which the copyright is owned by a third party has been clearly labelled. The Department has made all reasonable efforts to ensure that this material has been reproduced in this print-based resource and the accompanying website with the full consent of the copyright owners.

Requests and enquiries concerning the Department's copyright material should be addressed to:

The Copyright Officer
Department of Education, Employment and Workplace Relations
Location code C148CW2
GPO Box 9880 Canberra ACT 2601
Email: copyright@deewr.gov.au

Questions about the design and content of the resource itself should be addressed to the project manager:

David McElvenny
Workspace Training
PO Box 1954 Strawberry Hills, NSW, 2012
Email: david@workspacetraining.com.au

About this resource

This learner guide is one of 11 learner guides developed for the *Kitchen and Bathroom Cabinetmaking* project, funded by the WELL Program in 2011-2012. The guides are aligned to the following core and elective competencies from the *Certificate III in Cabinetmaking (Kitchens and Bathrooms) LMF32109*:

| | |
|---------------------|--|
| <i>LMFKB2001A</i> | <i>Prepare for cabinet installation</i> |
| <i>LMFKB3001A</i> | <i>Identify processes in kitchen and bathroom</i> |
| <i>LMFKB3002A</i> | <i>Determine requirements for installation</i> |
| <i>LMFKB3003A</i> | <i>Check and measure fit of cabinets</i> |
| <i>LMFKB3004A</i> | <i>Conduct on-site adjustments to cabinets</i> |
| <i>LMFKB3005A</i> | <i>Fabricate cabinets for the built-in environment</i> |
| <i>LMFKB3006A</i> | <i>Install fitted cabinets and components</i> |
| <i>LMFFM3006B</i> | <i>Install furnishing products</i> |
| <i>MSAENV272B</i> | <i>Participate in environmentally sustainable work practices</i> |
| <i>MSAPMOHS200A</i> | <i>Work safely</i> |
| <i>MSAPMOPS101A</i> | <i>Make measurements</i> |

The purpose of the guides is to help apprentice cabinetmakers acquire the background knowledge needed to satisfy the theoretical components of these units. However, they are not designed to replace the practical training necessary to develop the hands-on skills required. Learners will still need to receive extensive on-the-job training and supervision before they will be ready to be formally assessed in these units.

E-learning version

All of these units are also available in an e-learning format, which contains additional photos, interactive exercises and a voice-over narration of the text. The e-learning version can be viewed live on the web at:

<http://www.kbcabinetmaking.com.au/>

The web version can also be purchased on a CD at a cost-recovery price from the project developer:

David McElvenny (project manager)
Workspace Training
PO Box 1954 Strawberry Hills, NSW, 2012
Email: david@workspacetraining.com.au

Acknowledgements and disclaimer

Project team

Project manager: David McElvenny

Instructional design: Kath Ware

Technical developer (website): Jim Vaughan

Assistant technical developer (and voice-over artist): Alex Vaughan

Quality assurance consultant: Giselle Mawer

Industry coordinator: Gary Dunshea (MSA Industry Skills Council)

Lead advisor: Rob Cole (Furnishing Industry Association of Australia)

Technical Advisory Group

New South Wales

Brad Holmes – Hunter TAFE

Grant Cohen – Hunter TAFE

Dean Brakell – Furnishing Industry Association of Australia

Warren Peters – South West Sydney Institute of TAFE

Sean Greening – South West Sydney Institute of TAFE

ACT

Martin Jud – Canberra Institute of Technology

Victoria

Bryon Stanley – Furnishing Teacher's Advisory Group (VIC, SA, TAS)

Richard Brooks – Cabinet Makers Association

Simon Hampton – Wodonga TAFE

John Simpson – Holmesglen TAFE

Tasmania

Stephen Kirkman – Skills Institute Tasmania

Queensland

Rob McAdam – Skills TECH Australia

Brad Buhse – Skills TECH Australia

Roberto Viola – Gold Coast Institute of TAFE

South Australia

John Holst – Marlestone TAFE

Dean Hart – Mt Gambier TAFE

Martin Videon – Furnishing Industry Association of Australia

Northern Territory

Hermann Oltrop – Charles Darwin University

Western Australia

Garry Michels – Polytechnic West

Keith Campbell – Polytechnic West

Adrian Boyling – Polytechnic West

David Boaden – Polytechnic West

Lorenzo Procopio – South West Institute of Technology

National

Laurie Kruize – Housing Industry Association

Photographs and graphics

All photos were taken by David McElvenny. All graphics were drawn by Kath Ware. We would like to thank the following companies for allowing us to take photos of their installers and workshop employees and generously providing technical advice:

Canobolas Kitchen Designs

Flair Kitchens

Danson's Kitchens and Joinery

Lamtex Innovative Furniture

Fewings Joinery

Stateline Cabinets

B&B Joinery

Ian McConnell Constructions

Krauss Kitchens

Financial contributions

This resource was largely funded by the Workplace English Language and Literacy Program, through the Department of Education, Employment and Workplace Relations. However, due to the scale of the project and the provision of print-based and website resources, additional financial assistance was provided by the following organisations:

Manufacturing Skills Australia (Industry Skills Council)

Furnishing Industry Association of Australia



Disclaimer

The content of this learner guide is provided for educational purposes only. No claim is made as to the accuracy or authenticity of the content. The views expressed in this publication do not necessarily represent the view of the Minister for Education or the Australian Government. The Australian Government does not give any warranty nor accept any liability in relation to the contents of this work.

Table of contents

| | |
|--|-----------|
| Introduction..... | 1 |
| Section 1 Making adjustments | 3 |
| Overview..... | 5 |
| Doors..... | 6 |
| Drawers | 9 |
| Panels and bench tops | 11 |
| Assignment 1 | 13 |
| Section 2 Using tools on-site | 15 |
| Overview..... | 17 |
| Hand tools | 18 |
| Power tools..... | 20 |
| Safety with power tools..... | 23 |
| Assignment 2 | 25 |
| Practical demonstration..... | 28 |

Introduction

In general, kitchen and bathroom installers prefer to do as much preparation as possible back at the workshop, where all the materials and specialised tools they need are on hand. But there are always some adjustments that have to be made on-site, either before the cabinets are physically put in position, or after they have been installed.

These final adjustments include lining up doors and drawer fronts so that the gaps are even and all vertical edges are plumb. They also include adjusting moving parts so that they operate freely and smoothly. On some jobs they can involve re-cutting panels or shaping filler strips to deal with problems in the walls or other existing parts of the building.



In this unit, we'll look at the most common sorts of adjustments that need to be made on-site during the installation process. We'll also talk about the hand-held tools that installers typically use to do this work.

Preparing for this unit

This unit follows on from *Checking fit of cabinets*, where the process of measuring cabinets and checking their fit 'in-situ' is covered. If you haven't completed *Checking fit of cabinets* already, you should undertake it now, before commencing this unit.

Working through the unit

There are two sections in this unit:

- Making adjustments
- Using tools on-site

Each section contains an *Overview*, an *Assignment*, and *Lessons* which cover the content material. Your trainer may ask you to submit the assignments as part of your assessment evidence for the unit. You will find hard-copy templates for these assignments in the separate *Workbook*.

Electronic 'Word' templates of the assignments are available on the website for this resource, at: <http://www.kbcabinetmaking.com.au/>

The electronic versions can be completed on-screen and sent to the trainer either as:

- a printed hard copy, mailed through the post
- an electronic file, emailed as an attachment.

Practical demonstration

Your final assessment of competency in this unit will include some practical demonstrations. Their purpose is to assess your ability to put your knowledge into practice and physically carry out the process of adjusting cabinets and other components on-site, using a range of hand held tools. To help you get ready for these hands-on assessment activities, there is a *Practical demonstration* checklist at the back of this Learner Guide.

The checklist sets out the sorts of things your trainer will be looking for when you undertake the practical demonstrations. Make sure you talk to your trainer or supervisor about any of the details that you don't understand, or aren't ready to demonstrate, before the assessment event is organised. This will give you time to get the hang of the tasks you will need to perform, so that you'll feel more confident when the time comes to be assessed.

Section

1

Making
adjustments



Overview

Some jobsites have problems with walls and floors that aren't square or level, or have localised deviations in their surfaces. Although some of these issues can be dealt with when the cabinets are manufactured in the workshop, other problems are best handled on-site where components can be shaped to achieve an exact fit.

The hardware systems used in the construction of cabinets also have a bearing on the adjustments that may need to be made on-site. There are various patented systems on the market for drawer slides and other moving parts which often have specialised methods for fitting and adjusting.



In this section, we'll talk about the typical adjustments that need to be made on-site by installers. Although we won't go into detail about specific adjustment techniques used with patented hardware systems, there will be the opportunity in the assignment for you to research and report on particular products used by your company.

Completing this section



The assignment for this section is designed to test your knowledge of the adjustment techniques used on-site and some common issues that installers are faced with. Have a look at *Assignment 1* on page 13 to see what you'll need to do to complete it.

There are also three lessons in this section:

- *Doors*
- *Drawers*
- *Panels and bench tops.*

These lessons will provide you with background information relevant to the unit of competency.

Doors

There is an enormous range of hinges available for cabinet doors. In practice, most of the cabinets you install will use a European-style concealed hinge. Nonetheless, you may still come across butt hinges of one type or another if you're working with traditional face-frame cabinets.

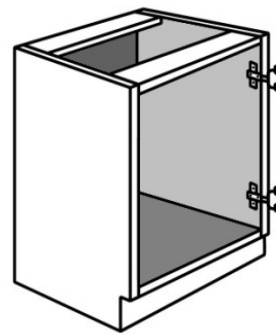

Frameless cabinet with concealed hinges

The pictures at right show the main difference between **face-frame cabinets** and European-style **frameless cabinets**.

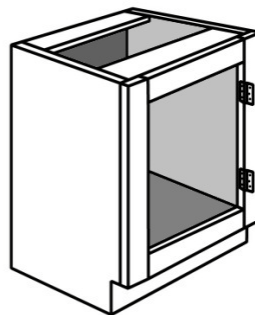

Face-frame cabinet with butt hinges

If you need to refresh your memory on these two construction methods, go back to the unit: *Processes in kitchen and bathroom projects*.

European-style hinges

European-style hinges are sometimes called **cup** hinges or **concealed** hinges. The hinge cup is mounted to the door, with the recess giving the hinge mechanism extra space to operate. The arm is attached to a mounting block screwed to the inside of the cabinet.

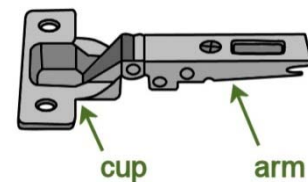

There are three main types of concealed hinges – **full overlay**, **half overlay** and **inset**. These names refer to the position of the door in relation to the side of the cabinet.

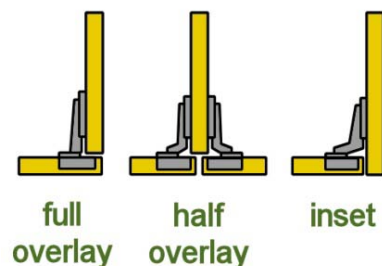

Adjusting the door

The drawing at right shows a typical concealed hinge with the door in an open position. The functions of the screws are as follows:

A: fixed door screws – used to permanently fix the hinge cup to the door.

B: adjustable cabinet screws – fixes the mounting

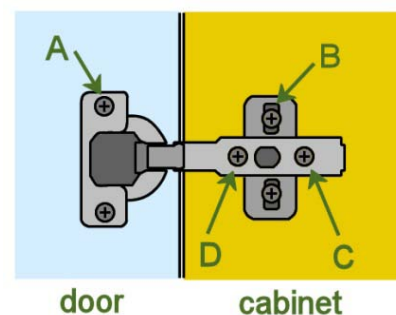

block to the inside of the cabinet, and allows the doors to be adjusted vertically (up and down).

C: locking screw – used to lock the arm in place once any sideways adjustments have been made (note that it needs to be loosened before screw D can be turned)

D: adjusting screw – used to adjust the door horizontally (from side to side)

To increase or decrease the **gap** at the side of the door, turn screw D in the same direction on both hinges for the door. The finished gap should be about 1-2 mm.

To adjust the **angle** of the door, turn screw D on either the top or bottom hinge, or if you need a bigger adjustment, turn the top screw one way and the bottom screw the other way.

If the door is **binding** (that is, touching the cabinet side as it closes), loosen the locking screw C on both hinges and slide the door outwards, away from the cabinet. Retighten the screws and check to see whether it has fixed the bind. Note that the gap only needs to be 1 mm between the door and the cabinet.

To adjust the **height** of the door, loosen the mounting block screws for both hinges (screw B) and move the door up or down.

In most cases, the cabinet door should be flush with the bottom of the cabinet and down about 4 mm from the top. This will provide clearance between the top of the door and the bench top. The door should also line up with the doors or drawers either side of it.

Always use a hand-held Phillips or pozi-drive screwdriver to make adjustments. Don't use a cordless drill, because it can easily strip the thread or burr the slots in the screw head.

Never try to **rack** the carcass – that is, push it sideways – to adjust the doors. This will simply send the cabinet out of square and make it harder to adjust the doors properly. Cabinets should always be installed level, plumb and square, regardless of the alignment of the floor or walls.

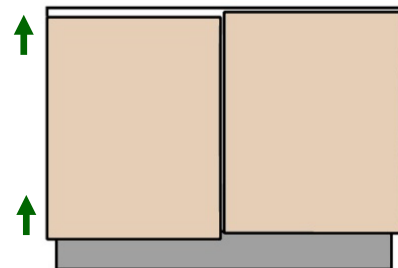
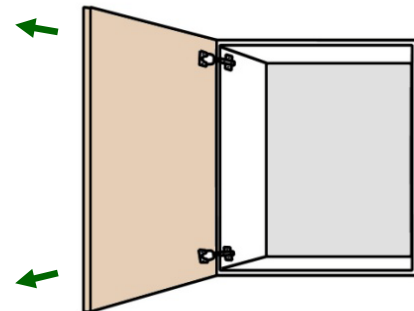
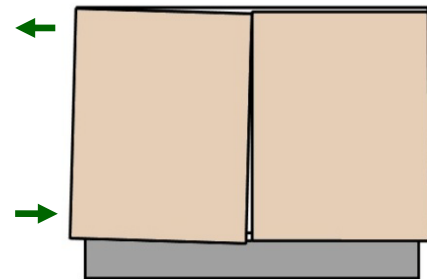

Learning activity



What are the main hinge types that you use in your cabinets?
List the three most common hinges and their manufacturer.

Choose the hinge that is most different from the concealed hinge described above, and briefly explain how you adjust the gap between doors. Share your answer with your trainer and other learners in your group. You may wish to take digital photos to help with your explanations.

Drawers

The drawers will probably have already been fitted before the cabinets were delivered to the jobsite. However, drawer fronts generally need a final adjustment on-site to match the gaps with adjacent cabinet doors or other panels.

There may also be times when a drawer runner needs to be re-adjusted because it wasn't lined up properly in the workshop.



Adjusting drawer fronts

Below are the procedures used to adjust drawer fronts on the two most common types of drawers.

Standard flat panel drawer

The standard drawer consists of 4 sides and a bottom, all made from 16mm melamine board. The drawer front is generally attached to the drawer in the workshop with 2 screws, fixed from the back. It can then be adjusted on-site by removing one of the screws and tapping the drawer front with a hammer and block of wood.

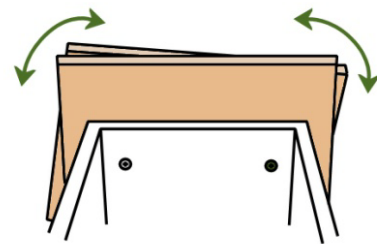

Once its position is correct, the front is secured with 3 more screws, making 4 screws in total.

Steel sided drawer

Steel sided drawers are manufactured in a range of patented designs. In most cases, the drawer front is attached separately.

The diagram at right shows a typical example of the bracket that connects the drawer front to the metal side. The functions of the screws are as follows:

A: adjusts the drawer front from side to side

B: attaches the drawer front to the metal side

C: adjusts the drawer front up or down.

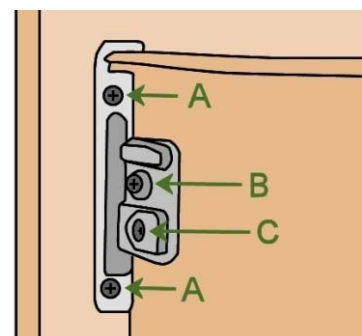

Adjusting drawer runners

There are various types of drawer runners available, ranging from simple runners to 'servo-drive' (electrically driven) drawer slides. Below is the procedure for re-aligning a standard drawer runner:

1. Unscrew all of the runner screws, except for the rear screw so that the runner can pivot at the back.
2. Put a level on the runner (assuming the cabinet is already level) and mark the new holes for the screws. You can either do this with a bradawl, or use a pencil and then drill pilot holes with a cordless drill.
3. Screw the runner back in place using the new holes.

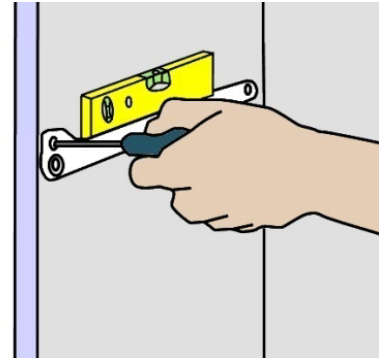

Learning activity



Your own company is likely to use a range of proprietary products made by a particular manufacturer, such as Blum, Hettich, Hafele or Lincoln Sentry. The options will cover various budgets and customer requirements, ranging from low-cost conventional fittings to high-end designer products.

What types of drawer runners and drawer front fittings do you use? Name the manufacturer and product title of each fitting. What advantages (if any) do they have when it comes to making final adjustments on-site? What tools are needed to make the adjustments?

Share your answers with your trainer and other learners in your group. You may wish to take digital photos to include with your descriptions.

Panels and bench tops

If you need to fit a panel or bench top to a wall and the corner isn't square, or the wall has deviations in it, you may need to shape the panel before it will fit tightly.

When you're working with panels that have visible edges butting up against a wall, you should try to achieve a gap of no more than 2 mm at the worst point.

The procedure for scribing and cutting a panel to get a tight fit is exactly the same as for making a template. The only difference is that now you're working directly with the piece that needs to be fitted.

We talked about the process of making templates in the unit *Checking fit of cabinets*. You should go back to that unit if you're unsure about how templates are used or have forgotten the basic principles involved.

Scribing and shaping a panel

To scribe a panel to the shape of a wall, you need some form of spacer to guide the pencil or marker. The spacer needs to be slightly thicker than the gap at its widest point.

Some installers simply use a small block of wood, but you can buy specialised scribing tools that are adjustable to suit different situations. For complex contours, such as scribing around a cornice, you can also use a compass or copy jig.



Set out below is the general procedure for scribing and shaping a panel.

1. Hold the panel in place, hard against the wall it needs to be fitted to.
2. Scribe the line by sliding the block along the wall and keeping the pencil or marker pressed against the other side, so that the line follows the contours at the correct spacing.
3. Cut or shape the panel using the appropriate tool, such as a jig saw or electric plane. Make sure you clamp the panel securely to a saw stool or work bench

and wear all required PPE while using the tool. It's also best to do the cutting outside if possible, to minimise the amount of sawdust that you need to clean up later.

4. Check the fit by holding the panel back in position. If the gap is still too wide at any point, draw a pencil line along the high spots of the panel, using the side of the pencil to maintain the correct spacing.
5. Re-cut the panel.

We'll talk more about using jig saws and electric planes in the next section of this unit.

Using silicone

For small gaps between a panel and a wall, it is common practice to use a bead of silicone to fill the gap. The silicone comes in a cartridge and is applied with a caulking gun. It takes some practice to get a smooth and even flow when applying the silicone bead, but it is a quick and economical way to finish the job.

Learning activity



Ask your supervisor what the process is in your company for scribing panels and bench tops. Do your installers use special marking tools, a compass, or a pencil and packing piece? Do they use different tools for different purposes?

Share your answers with your trainer and other learners in your group.

Assignment 1

Question 1

Three different types of concealed hinge are shown below. Their names refer to the position of the door in relation to the side of the cabinet. What is the name of each type of hinge?

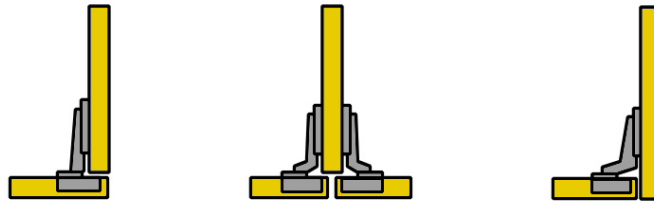

Question 2

Choose a concealed hinge that you commonly use in your cabinets and answer the following questions:

- Who is the manufacturer and what is the full name of the hinge?
- What is the standard gap that you try to achieve between doors?
- How do you fix a bind in the door with this type of hinge?

Question 3

Choose a drawer system that you commonly use and answer the following questions:

- How is the drawer front fixed to the drawer? If it uses a patented system, name the manufacturer and the product. If it is a standard workshop-built drawer, describe the process for fixing the front.
- If a drawer front was high on one side in the finished cabinet, how would you drop that side so the front was level?

Question 4

The cabinet below has been installed with a level top and base, but it has been pushed out of square because the wall is not plumb.

When the doors are hung, there will be a serious problem. Draw the two doors in position on the diagram to show what the problem will be.

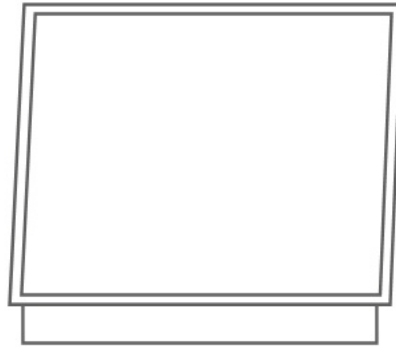
**Question 5**

The cabinet below has been installed with plumb sides, but it has been pushed out of square because the floor isn't level.

When the doors are hung, there will be a serious problem. Draw the two doors in position on the diagram to show what the problem will be.

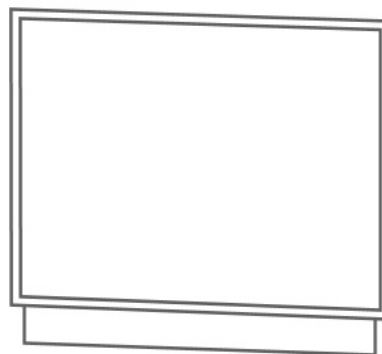

Note that the 'out of square' problems shown above have been exaggerated to illustrate the point. In practice the issue is not likely to be as pronounced, and in many cases may be almost invisible to the eye.

Section 2

Using tools on-site



Overview

Most of the tools and processes used by on-site installers are common to the carpentry trade. Unlike carpenters, however, cabinet installers work mostly with prefabricated units and panels, so they need to be very careful to protect the finished surfaces from damage or blemishes while they're making adjustments and re-shaping panels.

In this section, we'll look at some of the hand-held tools used on-site to carry out adjustments, and discuss tips and precautions that apply to them. The tools will include ordinary 'hand' tools such as hammers and chisels, and hand-held power tools, such as circular saws and planes.



Completing this section



The assignment for this section is designed to test your understanding of the processes involved in using power tools to shape or re-cut panels and components. Have a look at *Assignment 2* on page 25 to see what you'll need to do to complete it.

There are also three lessons in this section:

- *Hand tools*
- *Power tools*
- *Safety with power tools.*

These lessons will provide you with background information relevant to the unit of competency.

Hand tools

The hand tools that you use to carry out adjustments on-site will depend on the type of installation you're doing and the materials you're working with. Below are some of the most common tools used by installers.

Claw hammer

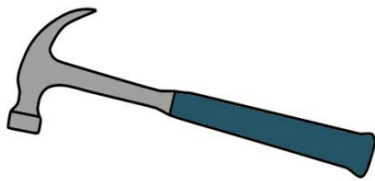

A claw hammer is basically designed for driving in and pulling out nails. It is also used for hitting chisels and punches, and tapping components into position.

Always use a block of wood to protect finished surfaces if you need to tap them with a hammer. Soft timbers can end up with '20 cent piece' indentations if you're not careful, and laminates can crack, indent or chip.

Screw driver



Screwdrivers come in a range of head types, the most common being 'flat' (also called 'standard') and Phillips.

Be sure to use the correct sized head for the screw you're turning. If the head is too small or too big for the screw, it can easily slip out and damage the screw slot or scratch nearby surfaces.

Bradawl



A bradawl is used to prepare a small hole for a screw, and is particularly useful when you need to break through a melamine surface by hand. To use a bradawl, push the head into the material while you're twisting it back and forth.

Chisel

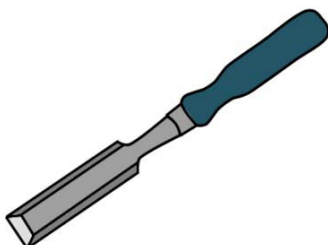

Chisels have a sharp edge designed for cutting wood. You can cut other materials with a chisel, such as melamine-faced particleboard, but it will blunt your chisel more quickly.

Keep your chisels sharp, and hone them regularly while you're working. When you're not using the chisel, make sure the edge is well protected from anything that might burr or blunten it, especially when it goes back into the toolbox. This could include putting a cap on the end or rolling it up in a protective bag.

Learning activity



Sharp chisels are a joy to use. Blunt chisels, by contrast, don't cut cleanly and can be downright dangerous if you have to apply excessive force to use them. So good hand-sharpening techniques with an oilstone are an essential part of every cabinetmaker's professional skills.

What are your skills like with hand sharpening? If you're unsure about the proper techniques to use, ask your supervisor or trainer for assistance. If you're already confident with your general technique, it's still worth practising your skills and trying to get the best result possible each time you hone the edge.

Power tools

The most common energy source used in hand-held power tools is 240 volt 'mains' electricity. However, as the performance of rechargeable batteries continues to improve, the range of 'cordless' power tools is ever increasing.

These days, just about every hand-held 240 volt power tool on the market is also available in a cordless variety.

Nonetheless, most of these battery operated versions are not yet performing at a standard required by professional tradespeople – with the big exception of the variable speed drill.



Cordless drills are now used everywhere, because they are so light weight and convenient.

The tools described below all play a role in adjusting cabinets on-site, particularly when panels or bench tops need to be re-shaped or re-cut.

Circular saw

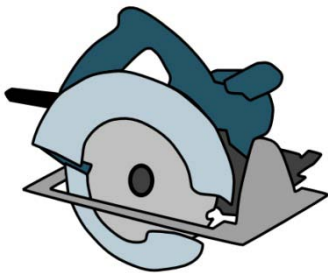

A circular saw is useful when you need to re-cut a panel, dock timber, or rip material lengthwise. Installers try to avoid using a circular saw to cut melamine or other laminate-faced panels whenever they can, because it's so hard to achieve a clean edge to the cut.

However, if you find that you've got no alternative to using a circular saw to re-cut a laminated board, the best advice is to:

- put the visible side of the board facing down while you're cutting so that the teeth cut upwards, which will reduce the chip-out on that side
- use a tungsten carbide tipped blade.

Plane

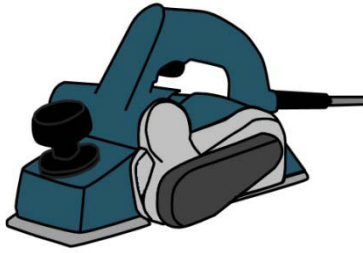

An electric plane is the best tool to use if you need to take a small amount of material off the edge of a panel, particularly if you're trying to accommodate a deviation in the wall or a tapered gap between the panel and wall.

The cutters should be kept sharp and free from any nicks or damage. Once they lose their sharpness, you should replace them straight away and have the old ones re-sharpened.

Jig saw

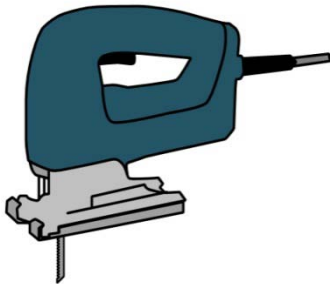

Jig saws are very manoeuvrable tools, and can cut curves, deviations and notches easily. There is a wide variety of blades available for different materials, including melamine and other laminates.

Like all power tools, you should make sure that the saw is allowed to cut at its own rate, without being forced through the material. This will help to avoid chip-out on the edge. It will also reduce the problem of the blade bending in the cut.

Drill



It's likely that you will take both 240 volt and cordless drills with you to the jobsite. The 240 volt drill will be used for the heavier work, such as drilling large holes or working with masonry.

The cordless drill will do everything else, including drilling small holes and inserting chipboard screws.

But just a reminder – as we said in Section 1, don't use an electric drill to turn adjusting screws in door hinges or to make other sorts of fine adjustments, because you could easily strip the thread or burr the slots in the head. Always use an ordinary screwdriver for this sort of work.

Learning activity



In the last two lessons we've looked at some of the most common hand and power tools used to make final adjustments to cabinets and components on-site. What have we missed?

Make up a list of any other tools you might need on-site to make adjustments or to re-shape panels prior to installation. Share your list with your trainer and other learners in your group.

Safety with power tools

Any tool has the potential to cause an injury, but power tools have several hazards that don't apply to simple hand tools.

Firstly, they are more powerful and much faster, so they produce reaction forces that can cause you to lose control if you're not extremely careful. Secondly, the power source itself is potentially dangerous if you come into direct contact with it. And thirdly, they often generate dust, sparks or flying particles that can cause serious problems if you don't take proper precautions.



Set out below are some basic principles for using power tools safely.

Basic safety procedures



1. Wear the correct personal protective equipment for the job at hand. This may include safety glasses, ear muffs and steel capped boots. Depending on the job, it might also include a dust mask and gloves.

Remove any loose clothing or jewellery, and tie back long hair.
2. Keep cutting edges sharp. Inspect the saw blade, drill bit or planer cutters before you plug in the tool, and make sure that they are in good condition, properly fitted and sharp.
3. Make sure that the guards are in place and correctly adjusted, and that spring-loaded mechanisms or other moving parts are working normally.
4. Secure the material firmly before you start the job. This could mean using a G-clamp or some other clamping system.
5. Always allow the motor to reach normal operating speed before letting the tool come into contact with the job. This helps to avoid the problem of 'kickback', and overloading the motor.
6. Always lift the tool clear of the job before turning off the motor. This helps to avoid the chance of the tool jamming in the job.



7. Wait until the motor has stopped and the guard has sprung back in place before laying the tool down.
 8. Listen to the sound of the motor when you start up the tool and while you're operating it.

If you hear any unusual sounds, stop the tool, unplug it, and look for the problem. If you can't fix it on the spot, tag the tool and take it to your supervisor or maintenance person for servicing.
 9. Keep the work area clear of off-cuts, sawdust build-up and rubbish that might get in the way.
10. Don't use electric tools in wet conditions. If it has been raining, or you're in a wet area, only use an electric tool if:
- your hands are dry
 - the tool is completely dry
 - you are wearing rubber soled boots and standing on a dry surface
 - electrical leads and connections are clear of damp ground.

Assignment 2

Task 1

This task deals with two scenarios where a vanity cabinet is being installed in the corner of a bathroom. In both instances the rear wall is out of plumb, but in opposite directions.

You have decided to hide the tapered gap between the cabinet and wall by fitting an end panel (the blue panel shown in the diagram at right).

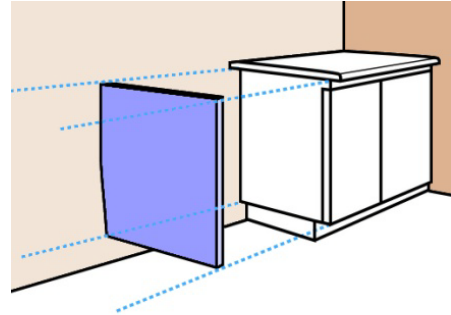

The end panel will go from the underside of the bench top to the bottom of the cabinet, above the kickboard. It will fit hard against the wall and finish flush with the front of the door. Although the wall is out of plumb, it is flat, so the tapered side of the end panel will form a straight line and won't need to be scribed.

You take the following measurements relating to the cabinet, and produce a quick detail drawing of each scenario (as shown in the diagrams below).

Bench top thickness: 35 mm

Height from top of kickboard to top of bench top: 765 mm

Width of cabinet (including door): 450 mm

Bench top overhang: 25 mm

Scenario 1

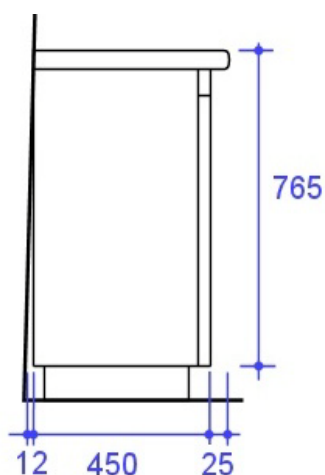

Scenario 2

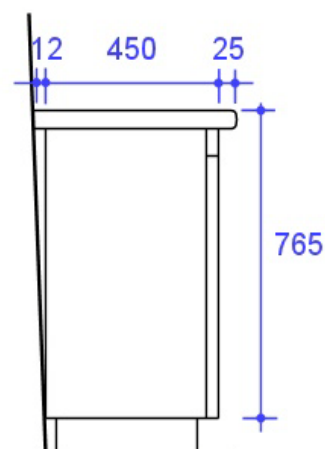

For each scenario:

- (a) draw the shape of the end panel
- (b) mark in the width of the panel at the top, width at the bottom, and height
- (c) mark the two corners that will be at right angles.

Task 2: Power tools

This Task is designed to help you to prepare for your practical assessment event, where you will be asked to demonstrate your ability to re-cut or shape a panel using one or more power tools. The tools you're likely to use will be an electric plane and a jig saw.

Choose either the plane or the jig saw and write up a brief safe operating procedure (SOP). See the sample SOP on the following page for an example of a completed SOP. This one is for a circular saw, so there are many similarities to the electric plane and jigsaw.

Use the template provided to write up your own SOP. You could look at the manufacturer's instruction booklet for more guidance or ask your supervisor for help.

Sample SOP: Circular Saw

Potential hazards and safety controls

| Hazard | Control |
|-------------------------------|---|
| Eye injuries | Wear safety glasses while using or standing near saw. |
| Hand and body injuries | Secure the material firmly before starting the saw. Cut with a straight, even motion – do not twist the saw in the cut. Always keep hands well clear of the blade. Lift the saw clear of the cut before releasing the trigger. Always stand to one side of the saw – not behind it. Maintain a correct stance and cut with even motion. Do not attempt to make cuts that are not appropriate for the saw. |
| Back injuries | Use good lifting practices when handling timber. Move your feet when turning to avoid twisting your body. |
| Noise | Wear hearing protection when using or standing near the saw. |

Pre-start checks

Check that:

- saw blade is sharp and in good condition,
- electrical lead and extension lead are in good condition,
- guard is sound and retracts and springs back properly,
- base plate is adjusted correctly for depth and angle of cut,
- saw starts up and runs normally, without any unusual noises or vibrations.

Operational procedure

1. Secure the material to be cut so that it cannot move.
2. Position feet to give a comfortable balance and rest the base plate of the saw in position.
3. Start the saw and allow it to reach full speed before commencing the cut.
4. Push the saw smoothly and continuously through the cut, allowing the blade to come out the other side before releasing the trigger. Keep power lead clear of the saw path.
5. Secure any large offcuts before they are allowed to break or snap off.

Practical demonstration

The checklist below sets out the sorts of things your trainer will be looking for when you undertake the practical demonstrations for this unit. Make sure you talk to your trainer or supervisor about any of the details that you don't understand, or aren't ready to demonstrate, before the assessment event is organised. This will give you time to get the hang of the tasks you will need to perform, so that you'll feel more confident when the time comes to be assessed.

When you are able to tick all of the YES boxes below you will be ready to carry out the practical demonstration component of this unit.

Practical demonstration checklist

You will be asked to carry out a range of on-site adjustments to kitchen or bathroom cabinets. Your trainer will need to see you do these activities over a period of time, to make sure that you are satisfying these 'demonstration criteria' consistently under different conditions.

| Demonstration criteria | YES |
|---|--------------------------|
| 1. Follows all company safety policies and procedures while at work and any additional site-specific policies while at the jobsite. | <input type="checkbox"/> |
| 2. Selects the correct tools and equipment for the work to be undertaken and checks that they are in good working order. | <input type="checkbox"/> |
| 3. Identifies the cause of problems in alignment and excessive or tapered gaps. | <input type="checkbox"/> |
| 4. Selects the most appropriate method to carry out adjustments and fit cabinets with the minimum of re-working. | <input type="checkbox"/> |
| 5. Uses hand and power tools efficiently. | <input type="checkbox"/> |
| 6. Adjusts door hinges correctly, checking that gaps and alignments are within industry standards and doors move freely and close properly. | <input type="checkbox"/> |
| 7. Adjusts drawer fronts and runners correctly, checking that gaps and alignments are acceptable, and drawers operate smoothly. | <input type="checkbox"/> |
| 8. Checks that handles and latches are properly aligned and are operating normally. | <input type="checkbox"/> |

-
9. Re-cuts or shapes panels, filler pieces or bench tops, and ensures that the final fit is within industry tolerances.
10. Cleans up the work area and disposes of rubbish.